

ES260
Floor Scrubber
Traction Driven
Brush Driven

Model #:
E260TDQP, E260TDCE,
E260TDQPIW,
E260BDQP, E260BDCE

OPERATION

SERVICE

PARTS

CARE

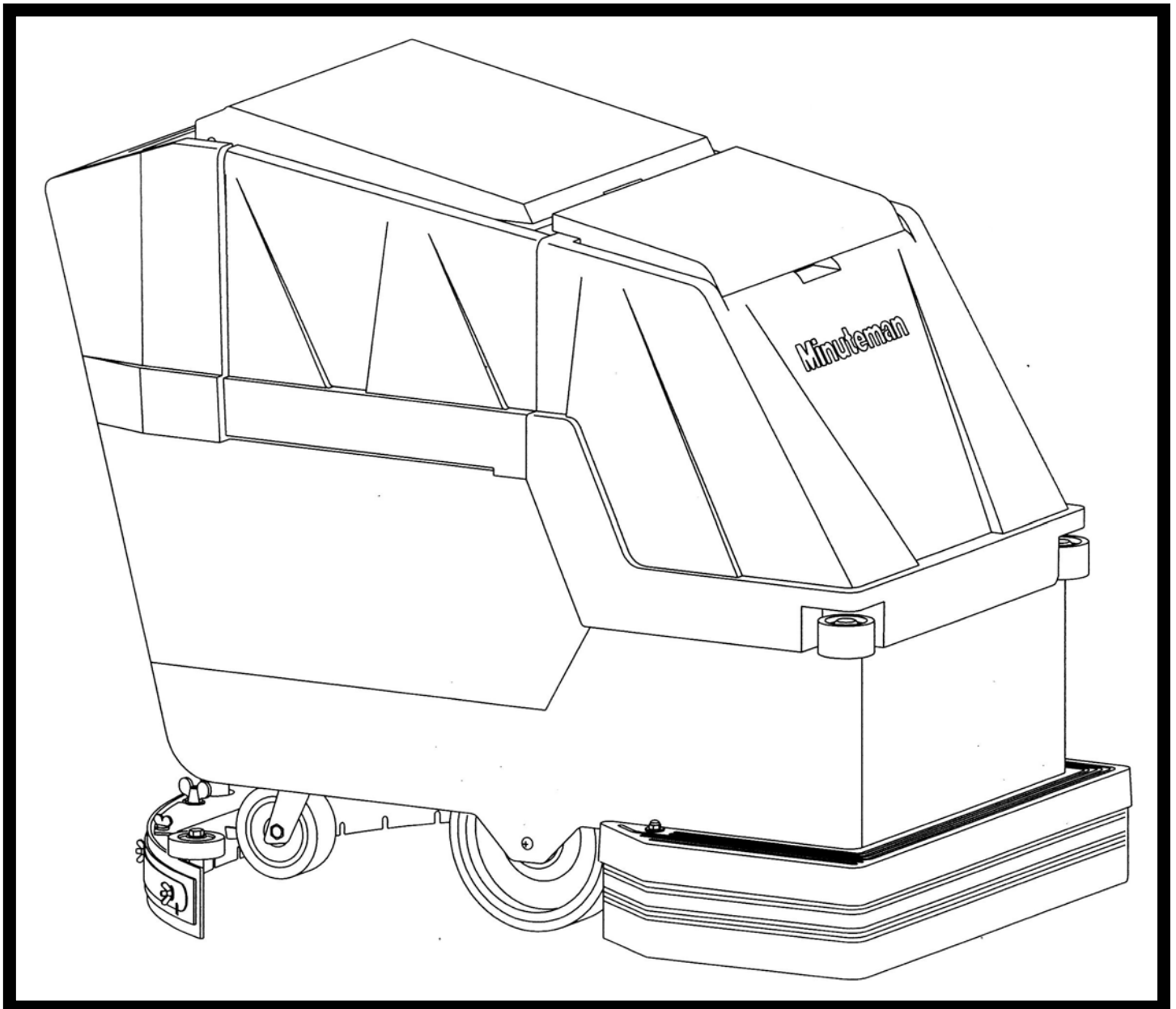

Minuteman[®]

TABLE OF CONTENTS

IMPORTANT SAFETY INSTRUCTIONS	3
ELECTRICAL REQUIREMENTS	4
CONTROL PANEL IDENTIFICATION.....	5
OPERATING INSTRUCTIONS	6
MAINTENANCE	6
REAR SQUEEGEE	7
REAR SQUEEGEE ADJUSTMENT	8
MAIN ASSEMBLY	9
MAIN ASSEMBLY BOM.....	10
SOLUTION & RECOVERY TANK (BRUSH DRIVE)	11
SOLUTION & RECOVERY TANK BOM (BRUSH DRIVE)	12
MAINFRAME ASSEMBLY (BRUSH DRIVE).....	13
MAINFRAME ASSEMBLY BOM (BRUSH DRIVE).....	14
LINKAGE ASSEMBLY (BRUSH DRIVE).....	15
LINKAGE ASSEMBLY BOM (BRUSH DRIVE)	16
CONTROL PANELS (BRUSH DRIVE).....	17
CONTROL PANELS BOM (BRUSH DRIVE).....	18
SOLUTION & RECOVERY TANK (TRACTION DRIVE)	19
SOLUTION & RECOVERY TANK BOM (TRACTION DRIVE)	20
MAINFRAME ASSEMBLY (TRACTION DRIVE).....	21
MAINFRAME ASSEMBLY BOM (TRACTION DRIVE).....	22
LINKAGE ASSEMBLY (TRACTION DRIVE).....	23
LINKAGE ASSEMBLY BOM (TRACTION DRIVE).....	24
CONTROL PANELS (TRACTION DRIVE).....	25
CONTROL PANELS BOM (TRACTION DRIVE).....	26
SQUEEGEE LIFT MECHANISM ASSEMBLY.....	27
SQUEEGEE ADJUSTMENT MECHANISM ASSEMBLY	28
SQUEEGEE BLADE ASSEMBLY	29
WIRING DIAGRAM (STANDARD MODELS).....	30
WIRING DIAGRAM (CE MODELS).....	32



DECLARATION OF CONFORMITY

MANUFACTURER'S NAME: Minuteman International Inc.

MANUFACTURER'S ADDRESS: 111 South Rohlwing Road
Addison, IL. 60101

EQUIPMENT DESCRIPTION: Automatic Floor Scrubbing Machines

EQUIPMENT MODEL DESIGNATION: E260TDCE, E260BDCE,
E320CE

Application of Council Directives: 98/37/EC, 89/336/EEC, 72/23/EEC

Harmonized standards complied with: EN 292, EN 60335-2-72, EN 55022,
EN 953, EN 60335-1:2002

SOUND		VIBRATION
77 dB Operator	74 dB At 3m	1.0 m/s ² At Operators Hand Grips

I, the undersigned, hereby declare that the equipment specified above conforms to the above Directive(s) and Standard(s).

SIGNATURE: Jeffrey Pollack **DATE:** 1/14/06

PRINTED NAME: Jeffrey Pollack
TITLE: Standards Engineer

IMPORTANT SAFETY INSTRUCTIONS

Operators must read and understand this manual before operating or maintaining this machine. Do not operate this machine in areas containing flammable or explosive materials.

This machine is designed solely for scrubbing dirt and dust in an indoor environment. Minuteman does not recommend using this machine in any other capacity.

The following information below may cause a potential hazard to the operator and equipment. Read this manual carefully and be aware when these conditions can exist. Take necessary steps to locate all safety devices on the machine and train the personnel operating the machine. Report any machine damage or faulty operation immediately. **Do not use machine if it is not in proper operating condition.**

FOR SAFETY DURING OPERATION:

Keep hands and feet clear of moving parts while machine is in operation.

Make sure all safety devices are in place and operate properly. All covers, doors and latches must be closed and fastened before use.

During operation, attention should be paid to other persons in the work area.

Electric motors and components can cause an explosion when operated near explosive materials or vapor. Do not operate this machine near flammable materials such as solvents, thinners, fuels, grain dust, etc.

Store or park this machine on a level surface only, with the key switch in the off position. To prevent unauthorized use, machine should be stored with the key removed.

This machine is designed for level operation only. **Do not operate on ramps or inclines.**

This machine is not suitable for picking up hazardous dusts.

Use caution when moving this machine into areas that are below freezing temperatures. Any water in the tanks or hoses can cause damage to the machine.

FOR SAFETY WHEN SERVICING OR MAINTAINING MACHINE:

Stop on a level surface and turn off the machine.

Disconnect the power to the machine by unplugging the large, red terminal below the recovery tank when charging batteries or during installation or removal of brushes.

Avoid moving parts. Do not wear loose jackets, shirts, or sleeves when working on machine.

Avoid contact with battery acid. Battery acid can cause burns. When working on or around batteries, wear protective clothing and safety glasses. Remove metal jewelry. Do not lay tools or metal objects on top of batteries.

Charging batteries generates explosive gasses. **Do not charge batteries when open flames or sparks are present. Do not smoke.** Make sure the charger is turned off before disconnecting it from the machine. Charge the batteries in a well-ventilated area with the battery cover removed completely.

Do not clean machine with a pressure washer.

Authorized personnel must perform repairs and maintenance. Use ONLY Minuteman supplied replacement parts.

SAVE THESE INSTRUCTIONS

ELECTRICAL REQUIREMENTS:

This piece of equipment operates on 24 VOLT DC.

BATTERY REQUIREMENTS:

4 x 6V, 275Ah batteries (Part Number 956740)

BATTERY SERVICE AND INSTALLATION

WARNING: Battery acid can cause burns. When working on or around batteries, wear protective clothing and safety glasses. Remove metal jewelry. Do not lay tools or metal objects on top of batteries.

BATTERY INSTALLATION:

1. Disconnect tank drain hose from rear of machine.
2. Raise the tank assembly by raising rear cover and tilting tank, Figure 1.
3. Install batteries as shown in Figure 2.

CHARGING BATTERIES:

Charging of batteries generates explosive gases. **DO NOT CHARGE BATTERIES WHEN OPEN FLAMES OR SPARKS ARE PRESENT. DO NOT SMOKE.** Make sure charger is turned off before disconnecting it from the batteries. Charge the batteries in well-ventilated area. Fluid levels should be checked before and after charging and maintained at the proper levels.

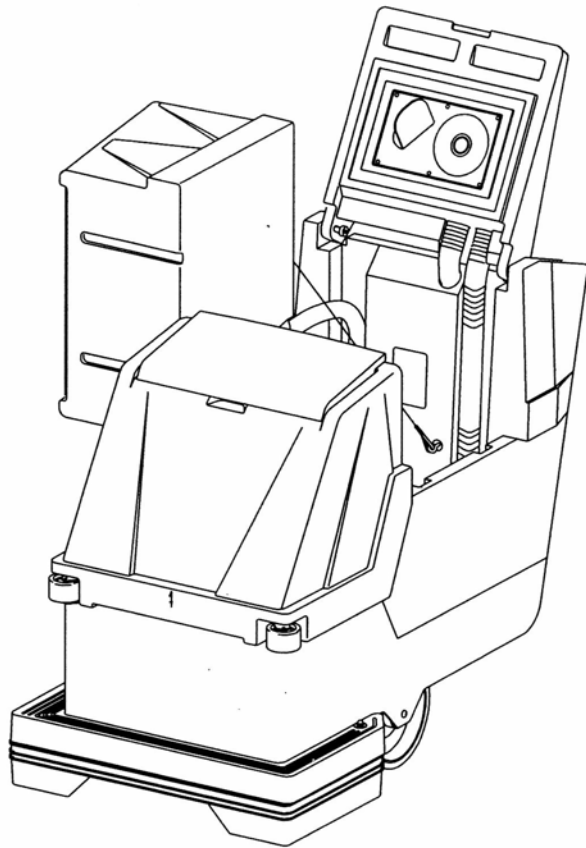

Figure 1

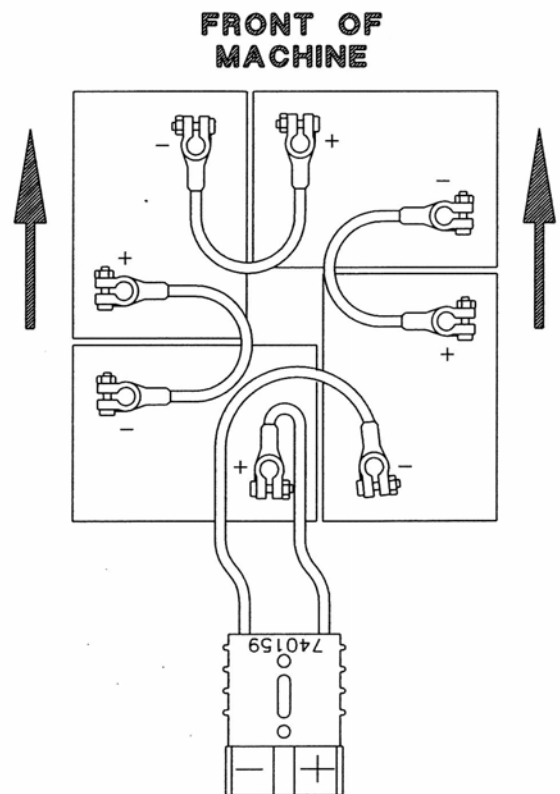
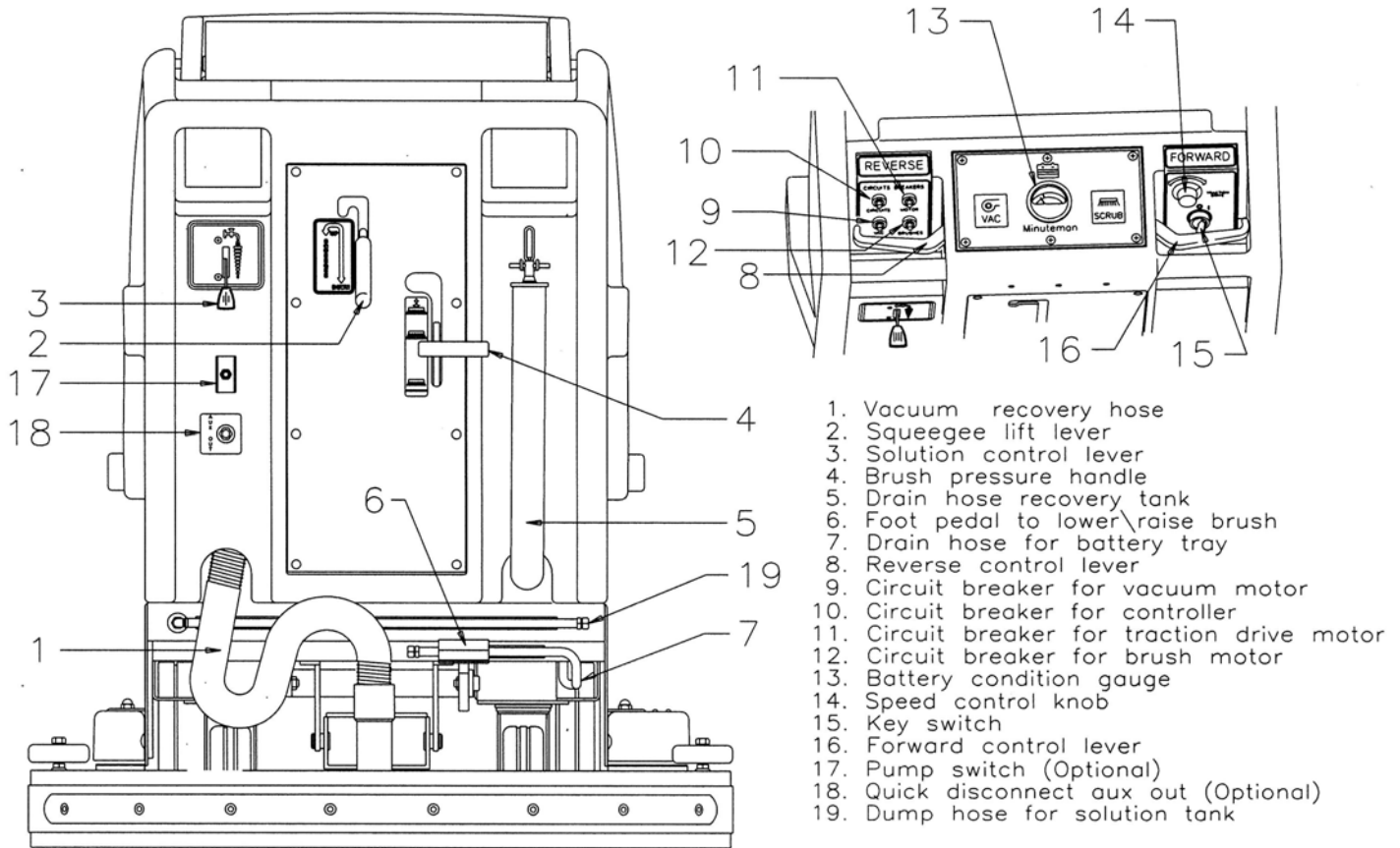

Figure 2

CONTROL PANEL IDENTIFICATION



AUTO SCRUBBER BRUSH DESCRIPTION

TYPE	DESCRIPTION	DURABILITY*	COLOR	COMPARISON TO PADS	RECOMMENDED USE
Bassine	Natural Fiber	Short	Dark Brown	Red	Light duty general cleaning, acid etching
Nylon	Nylon	Medium	Black	Tan/Red	General cleaning & scrubbing vinyl floors, ceramic tile & concrete floors
Dyna-Scrub	Nylon impregnated with 500 Grit Silicon Carbide Fine Bristle, Dense Fill	Long	Light Blue	Red	General scrubbing, vinyl tile, ceramic tile, epoxy floors, urethane finish, uneven concrete floors
Power-Scrub	Nylon impregnated with 120 Grit Silicon Carbide Fine Bristle, Dense Fill	Long	Rust	Red/Blue	Moderate aggressive scrubbing, tile floors concrete floors
Poly-Grit	Nylon impregnated with 80 Grit Silicon Carbide Coarse Bristle	Long	Green	Brown/Black	Aggressive stripping and scrubbing, tile floors, unfinished concrete floors
Strata-Grit	Nylon impregnated with 46 Grit Silicon Carbide Coarse Bristle	Long	Dark Blue	Black	Heavy duty stripping/scrubbing unfinished concrete

* Durability is dependent on floor surface, chemicals used and proper care.

OPERATING INSTRUCTIONS

1. Filling: Fill the solution tank with the desired amount of water and add liquid cleaning solution to the proper dilution ratio. DO NOT USE powdered cleaning chemicals. Powders are unlikely to dissolve thoroughly, resulting in clogging the in-line solution filter. This can reduce or stop water flow to the brush.
2. Close lid.
3. Turn on main power key switch (refer to page 5, #15).
4. Adjust main speed control knob (#14) to full counter-clockwise position. (Traction Drive Only)
5. Lower brush assembly:
 - Depress foot pedal (#6) slightly and push in on lever (#4) to release. To increase brush pressure, pull up and back on lever (#4) to lock position.
 - To lift the brush, press the pedal down until lift mechanism engages.
 - Brushes will begin to rotate when forward (#16) or reverse (#8) levers are engaged.
6. Adjust solution control feed lever (#3).
8. Lower squeegee assembly with lever (#2). This will turn on the vacuum motor. The vacuum will remain on until the squeegee lever (#2) is raised. After this, the motor will continue to run for an additional 10 seconds to clear the recovery lines.

Turning off the power using the key switch will immediately shut down all systems, including vacuum motor, transaxle, and solution feed.

9. Squeeze forward handle (#16), and adjust forward speed using control knob (#14). (Traction Drive Only)

After Use:

1. Raise brushes with foot pedal (#6), brushes and solution flow will turn off .
2. Raise squeegee assembly; vacuum will shut off 10 seconds after raising.
3. Solution and recovery tanks should be emptied after every use. These tanks can be emptied using drain hoses (#5 & #19).

MAINTENANCE

Daily:

1. Clean float assembly & squeegee blades.
2. Recharge batteries (check battery acid levels before and after charging).

Monthly:

1. Check wear on squeegee blades.
2. Grease front and rear wheels.
3. Grease pivot points on the brush motor assembly.

Every 500 hours check the condition of carbon brushes on vacuum motor and brush drive motor.

REAR SQUEEGEE

The rear squeegee is the main element that acts as the conduit that transfers the spent solution into the recovery tank. A daily maintenance check of this component is essential to have optimum machine performance. The rear squeegee assembly is equipped with a universal front blade that allows the operator the option to use a slotted and a non-slotted side for specific applications. Each blade configuration has two usable edges. The rear blade however has four usable edges.

The squeegee is pre-adjusted at the factory. Adjustments may be required to get optimum performance for different floors and conditions.

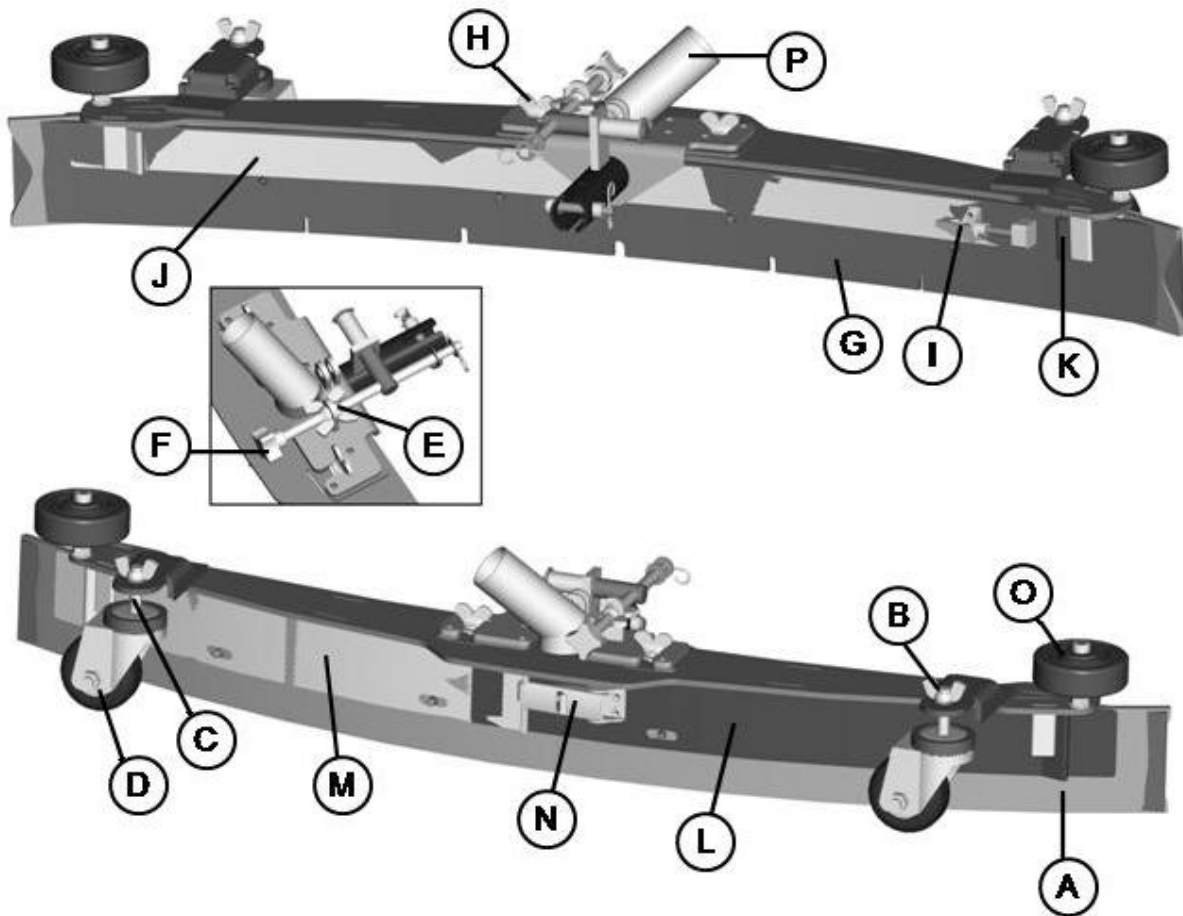

REAR SQUEEGEE COMPONENTS

A	Rear Squeegee Blade	I	Toggle Clamp
B	Wing Nut (2)	J	Front Strap (Long)
C	Caster Stem (2)	K	Front Strap (Short)
D	Swivel Caster (2)	L	Rear Strap (Latch Side)
E	Wing Jam Nut (2)	M	Rear Strap (Catch Side)
F	Turnbuckle Adjustment Knob	N	Latch
G	Front Squeegee Blade	O	Guide Wheel (2)
H	Wing Bolt (2)	P	Recovery Hose Intake

REAR SQUEEGEE ADJUSTMENT

1. Ensure that the scrubber is on a relatively flat surface. Turn on the key switch and lower the squeegee to the floor using the squeegee lift lever. This turns the vacuum motor on.
2. Move the scrubber one or two feet forward slowly while someone behind the machine checks the rear squeegee blade (item **A**) for uniform deflection to the floor.
3. If uneven deflection or lay is evident, minor adjustments may be necessary to avoid streaking and uneven wear on the blade.
4. To correct this, loosen the wing jam nut (item **B**) in order to adjust the caster height. If the squeegee blade is deflecting too much, the casters (item **D**) need to be lowered to control the down pressure. Lower the caster by turning the exposed threaded stem (item **C**) on the caster clockwise. Make the adjustment a few turns at a time. **Repeat step 2.**
5. If the blades are not deflecting enough, raise the caster by turning the stem counter-clockwise to adjust the caster height to allow more down pressure on the squeegee. **Repeat step 2.**
6. Make sure there is even deflection on the entire length of the rear blade. Adjust the casters and retighten the wing jam nuts to lock the caster setting in place.
7. Pitch adjustment is necessary if the outer ends on the squeegee blade do not contact the floor and there is too much deflection in the middle area or if the outer ends are over deflected and there is no contact in the middle.
8. To adjust the pitch, Repeat step 2.
9. Loosen the two wing jam nuts (item **E**) that lock the pitch angle. Turning the knob (item **F**) clockwise or counter-clockwise controls the forward and backward pitch of the squeegee. Having the rear blades deflected uniformly along its entire length is the desired set-up.
10. Repeat step 2 until desired set-up is achieved.
11. In certain applications where a non-slotted front wiper blade (item **G**) is needed, detach the rear squeegee assembly by loosening the two wing bolts (item **H**). Unlock the toggle clamp (item **I**) on the front squeegee to release the front long strap (item **J**) and slide the front short strap (item **K**). Flip the blade over to the non-slotted side. Reattach the straps and lock the clamp back in place.
12. You can also easily replace the rear blade by unlatching the latch (item **N**) and removing the two rear straps (items **L & M**) by sliding them off the assembly. You can then flip the blade over in order to use a new edge for better wiping action.

MAIN ASSEMBLY

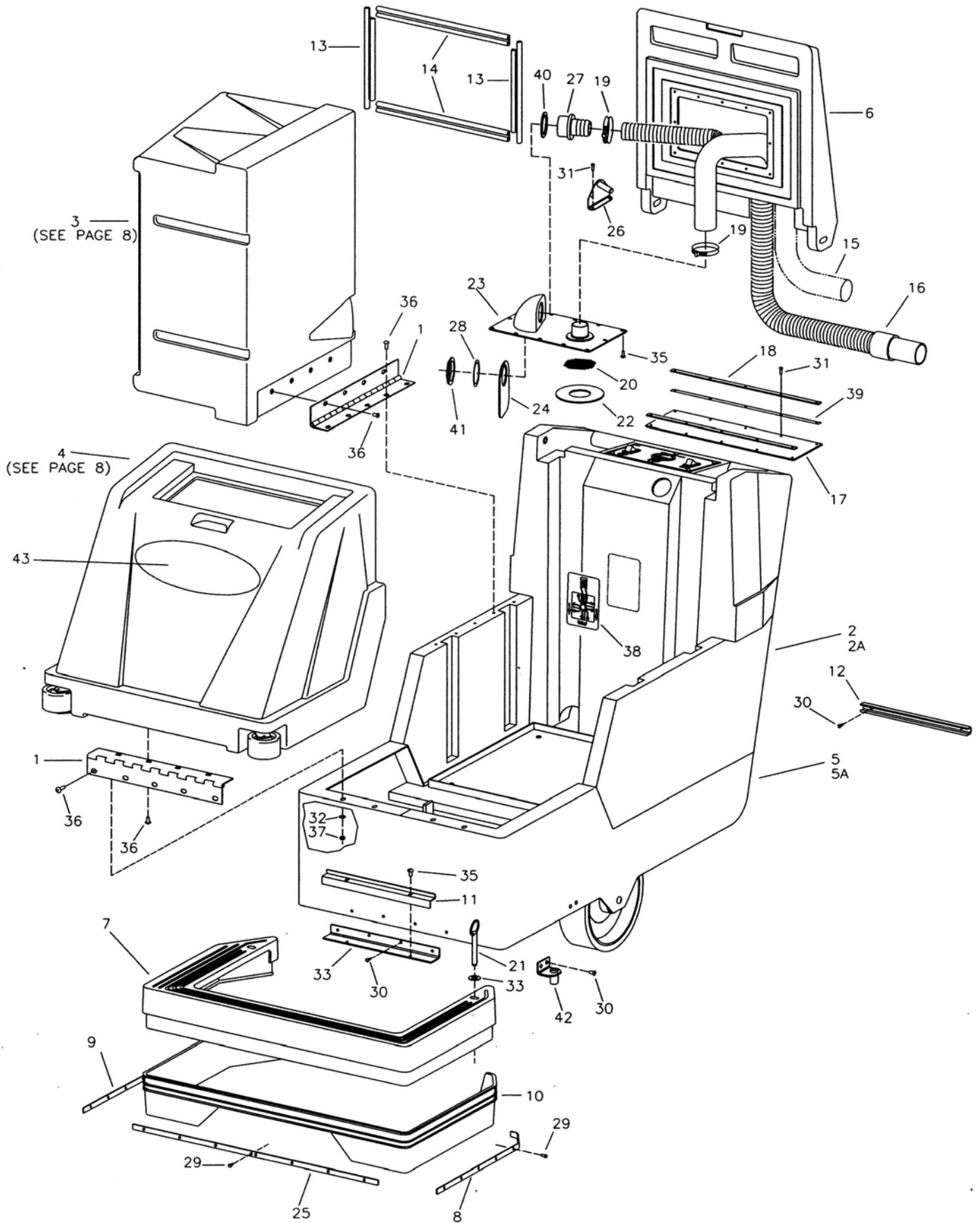

MAIN ASSEMBLY BOM

PARTS LIST			
ITEM	PART NO.	REQ'D	DESCRIPTION
1	260087	2	HINGE-15"
2	260090	1	REAR BASE CHAR GREY
2A	260256	1	BASE 260TD CHAR GREY
3	260091B	1	RECOVERY TANK, ES260320 BURGUNDY
4	260092B	1	SOLUTION TANK, ES260320 BURGUNDY
5	260093	1	CHASSIS MMAN 260
5A	260360	1	MAINFRAME MMAN 260 TD
6	260096B	1	LID RECOVERY 260 BURGUND
7	260098	1	FRNT SKIRT 260 BLACK
8	260142	1	SKIRT RETAINER, L SIDE
9	260143	1	SKIRT RETAINER R SIDE
10	260145	1	SPLASH SKIRT
11	260148	1	SOLUTION DUMP BKT 14GA
12	260149	1	U CHANNEL 12"
13	260157	2	LID GSKT SHORT 260B
14	260158	2	LID GSKT 260B
15	260159	1	HOSE-VAC 1.5 X 78" WIRELOC
16	260160	1	RECOVER HOSE ASY260B
17	260169	1	LID FLAP
18	260170	2	RETAINER STRIP
19	260203	2	CLAMP-HOSE 102120 MURRAY
20	260212	1	SCREEN FILTER
21	260241	2	PIN-HITCH 7/16 X 3
22	260294	1	GASKET 260
23	260299	1	SHUT OFF PLATE ASY
24	260301	1	DEFLECTOR FLAP
25	260336	1	SKIRT RETAINER - FRONT
26	260664	2	REC LID MOUNT WMT, ES260320
27	450037	1	ADAPTER MCH
28	450081	1	WSR 1.908 X 2.41 X .03 SS
29	711106	20	SCR-ST-A 10 X .75 PL
30	712530	10	SCR-MC 10-24 X .62 SS
31	711161	10	SCR-HI/LO #10 X 3/4 ZINC
32	711505	4	WSR-FLT 1/4
33	711508	2	WSR-FLT .44 X 1.00 X .08
34	260022	1	.125R 1S1B SKIRT MOUNT BRACKET
35	712540	14	SCR-MC 10-24 X .37 SS TH
36	712565	17	SCR-MC 1/4-20 X .62 SS
37	712667	4	NUT-HEX NYLOC 1/4-20 SS
38	715607	1	DECAL-BATTERY CABLE ROUT
39	760263	2	FOAM TAPE 1/16 X 1/2
40	828970	1	WSR NEOP 1.87X2.4X.125
41	828971	1	NUT 1 1/2 PIPE THREAD
42	260024	2	WELD-BRKT SKIRT
43	715841	1	DECAL, ES260320

SOLUTION & RECOVERY TANK (BRUSH DRIVE)

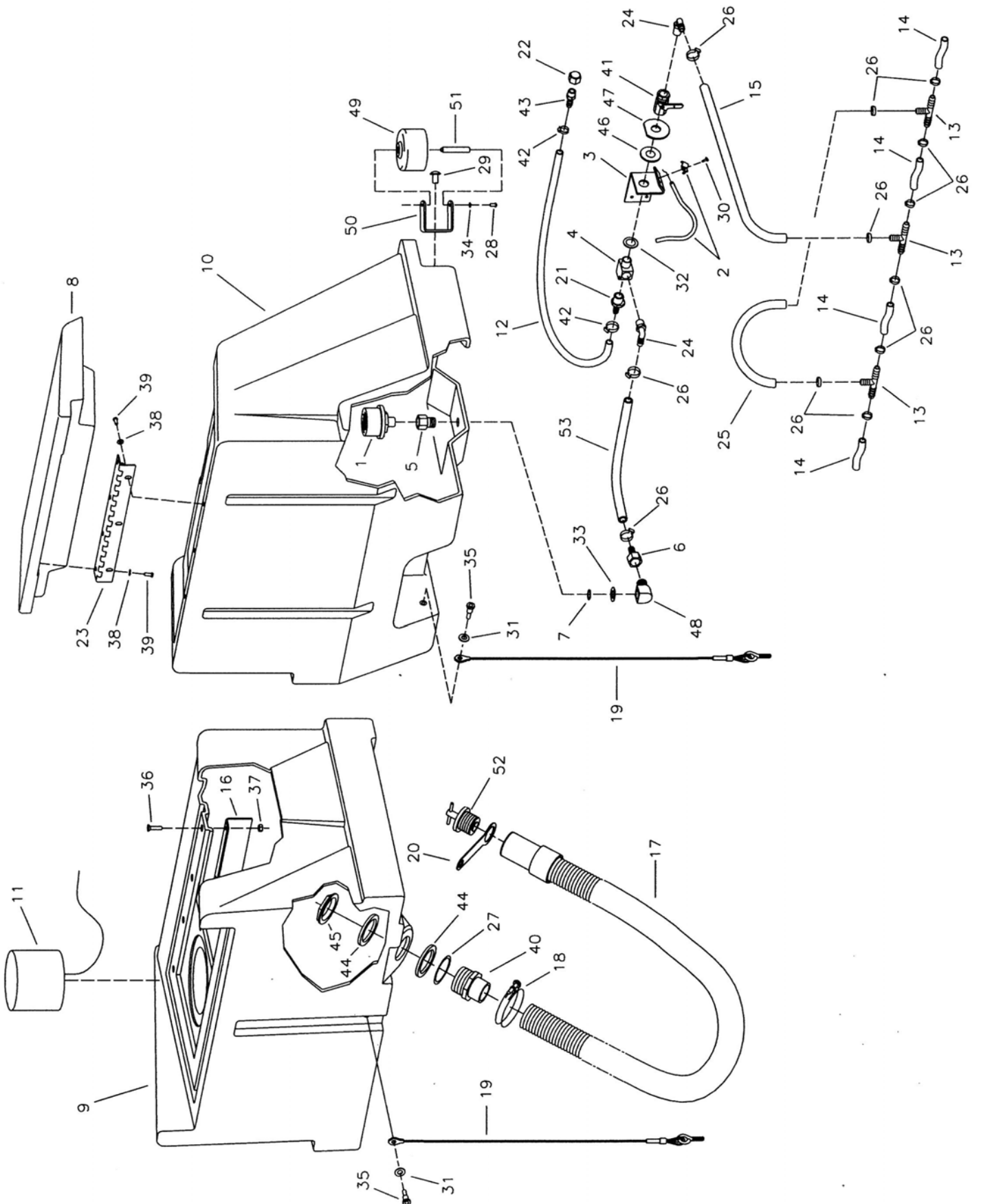

SOLUTION & RECOVERY TANK BOM (BRUSH DRIVE)

PARTS LIST			
ITEM	PART NO.	REQ'D	DESCRIPTION
1	130118	1	STRAINER-SOLUTION M3-40
2	210045	1	CABLE-SOLUTION CONTROL
3	210370	1	SOLUTION VALVE BRACKET
4	210408	1	FITTING BRASS TEE 3/8MPT&FPT
5	210409	1	FITTING BRASS 3/8MPT 3/8FPT
6	210410	1	FITTING BRASS 3/8FPT 3/8HOSE
7	210414	1	O RING 2-113
8	260029B	1	LID SOLUTION BURGUNDY
9	260091B	1	RECOVERY TANK 260 BURGUNDY
10	260092B	1	SOLUTION TANK 260 BURGUNDY
11	260156	1	FLOAT ASSEMBLY
12	260670	1	TUBING, PLASTIC 3/8 ID X 70"
13	260178	3	FITTING NYLON T 3/8HOSE
14	260179	4	HOSE-NYLOBRAID 3/8 X 2.38
15	260182	1	SOLUTION HOSE C/L 18"
16	260184	1	SUPPORT ANGLE
17	260202	1	HOSE ASY 260B NEW STYLE
18	260203	1	CLAMP-HOSE 102120 MURRAY
19	260214	2	TANK CABLE ASY 260
20	320269	1	STRAP, DRAIN PLUG RETAINING
21	342430	1	FITTING BRASS 3/8MPT 3/8HOSE
22	430114	1	FITTING NYLON CAP 1/4FPT
23	450021	1	HINGE
24	450040	2	ELBOW PLT 3/8MPTX3/8BARB
25	450055	1	HOSE NYLO 3/8ID X 9"
26	452037	12	CLAMP-CRIMP 170R SS
27	450081	1	WSR 1.908 X 2.41 X .03 SS
28	710353	2	SCR-MC 10-32 X .37 ZINC
29	710985	2	SC 3/8-16 X .62
30	711124	1	SCR-ST-B 10 X .37 NI
31	711506	2	WSR-FLT 5/16 (NARROW) ST PL
32	711512	1	WSR-FLT .75 X 1.37 X .08
33	711513	1	WSR-FLT .689 X 1.06 X .029 SS
34	711553	2	WSR-INT LOCK #10
35	712041	2	BLT-SHOULDER 1/4-20 X .44 X .3
36	712563	4	SCR-MC 1/4-20 X 1.00 SS
37	712667	4	NUT-HEX NYLOC 1/4-20 SS
38	712764	7	WSR #10 SS
39	712822	7	SCR-MC TR HD 10-24 X .50 SS
40	760220MCH	1	1.5 ADAPTER MCH
41	809413MCH	1	SOLUTION VALVE
42	828490	2	CLAMP-CRIMP 140R
43	828952	1	FITTING PP 1/4MPT 3/8BARB
44	828970	2	WSR NEOP 1.87X2.4X.125
45	828971	1	NUT 1 1/2 PIPE THREAD
46	828975	1	WSR NEOP .75X1.5X.09
47	829463	1	S S WASHER
48	830062	1	FITTING BRASS 90 3/8MPT 3/8FPT
49	832896	2	GUIDE WHEEL
50	832949	2	BRACKET BUMPER
51	833254	2	BUMPER WHEEL AXLE
52	833316	1	DRAIN PLUG
53	281637	1	HOSE-WIRE REINF 3/8 X 11"

MAINFRAME ASSEMBLY (BRUSH DRIVE)

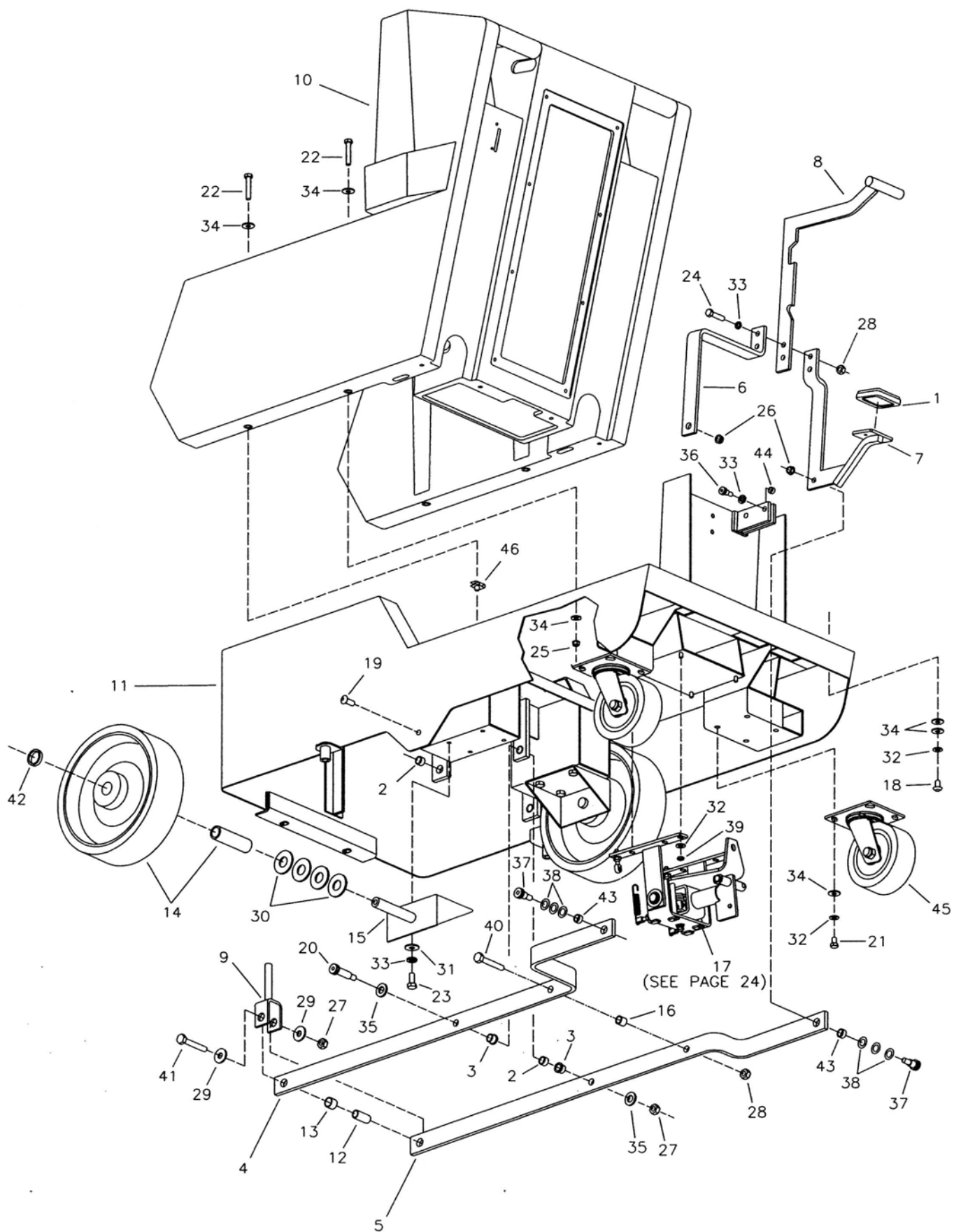

MAINFRAME ASSEMBLY BOM (BRUSH DRIVE)

PARTS LIST			
ITEM	PART NO.	REQ'D	DESCRIPTION
1	210142	1	PEDAL PAD
2	260030	5	BUSHING-.5015 X .628 X .375 OI
3	260041	2	BUSHING-FLG .502 X .750 X .375
4	260043	1	LIFT ARM, LEFT SIDE
5	260044	1	LIFT ARM, RIGHT SIDE
6	260046	1	PEDAL BRACE
7	260054	1	PEDAL WELDMENT
8	260055PTD	1	LIFT HANDLE WELDMENT
9	260075	1	YOKE WELDMENT
10	260090	1	REAR BASE CHAR GREY
11	260093	1	CHASSIS MMAN 260
12	260125	1	BUSHING-YOKE .407 X 1.687 STL
13	260128	1	SPACER-YOKE
14	260130	2	WHEEL 10" W/BUSHING
15	260136	2	WHEEL AXLE BKT ASY
16	260141	1	SPACER-LIFT ARM
17	260660	1	SQUEEGEE MECH ASSEMBLY
18	710196	4	SCR-MC 5/16-18 X .62
19	710986	2	SC 3/8-16 X 1 ZINC
20	710992	1	BLT-SHOULDER 1/2 X 1.25 X 3/8
21	711228	8	BLT-HH 5/16-18 X .75 STL ZINC
22	711232	4	BLT-HH 5/16-18 X 1.50
23	711242	8	BLT-HH 3/8-16 X 1.00
24	711250	2	BLT-HH 3/8-16 X 1.25 STL ZINC
25	711374	2	NUT-NYLOC 5/16-18
26	711375	2	NUT-NYLOC 3/8-16 1/2NUT
27	711380	2	NUT-NYLOC 3/8-16
28	711439	3	NUT-FLANGED WIZZ 3/8-16
29	711507	2	WSR-FLT .37 X 1.12 X .06
30	711512	8	WSR-FLT .75 X 1.37 X .08
31	711515	8	WSR-FLT .406 X .812 X .0625
32	711545	16	WSR-HELICAL 5/16
33	711546	12	WSR-HELICAL 3/8
34	711575	22	WSR-FLT .31 X .75 X .06 STL
35	711579	2	WSR-FLT .56 X 1.00
36	712081	2	BLT-SHOULDER 5/16-18 X .75 X .
37	712099PLT	2	BLT-SHOULDER 1/2 X 1/2
38	712310	6	WSR-FLT .52 X .87 X .06 PL
39	712680	4	NUT-HEX 5/16-18 SS
40	713045	1	BLT-HH 3/8-16 X 1.75 #5
41	713048	1	BLT-HH 3/8-16 X 2.50 #5
42	762107	2	SPACER-1.00 X 1.25 X .25
43	762340	2	BUSHING-.502 X .625 X .270 STL
44	809247	2	SPACER-.442 X .50 X .312
45	827110	2	CASTER 5 INCH
46	832829	2	NUT-U TYPE 5/16 X 18

LINKAGE ASSEMBLY (BRUSH DRIVE)

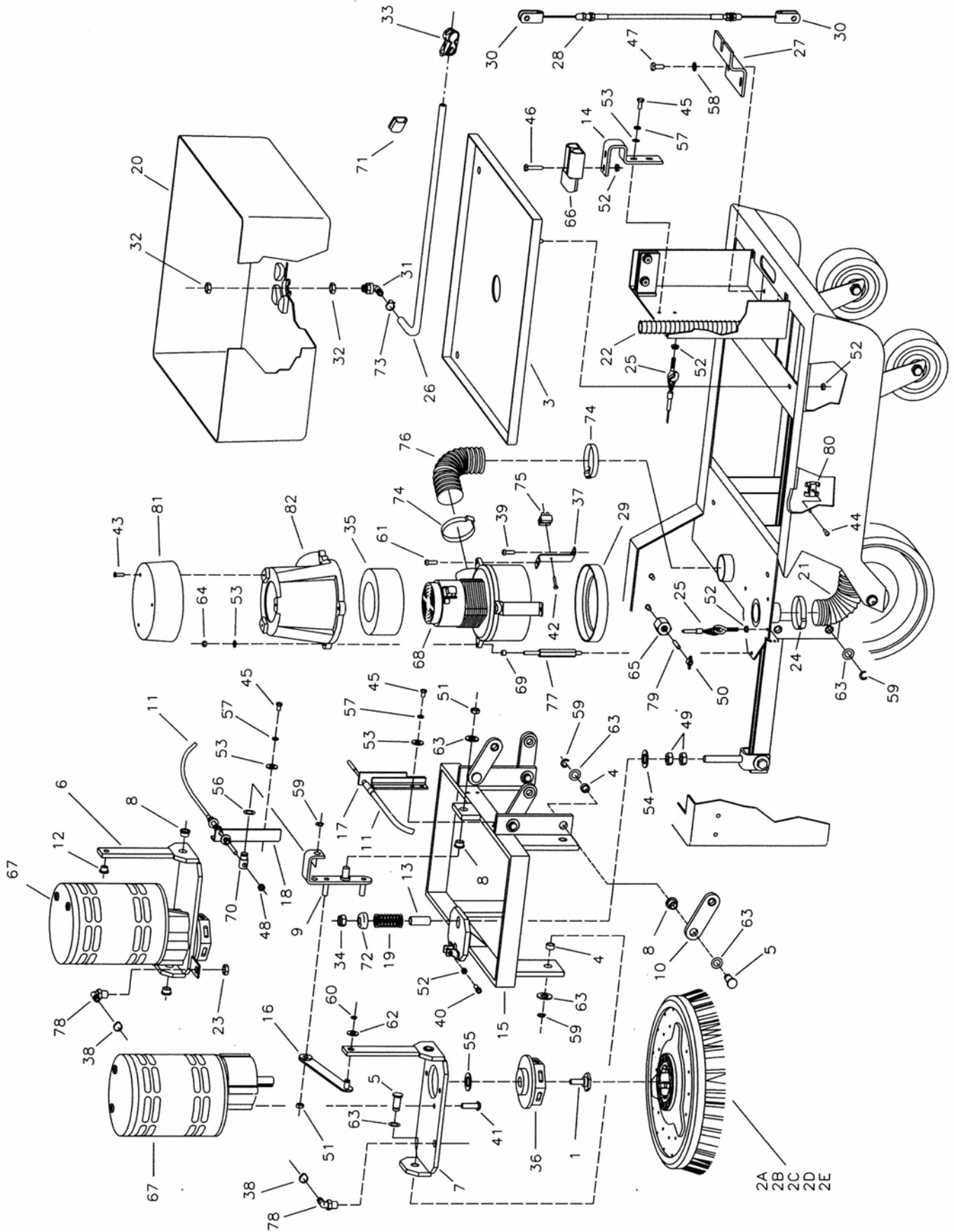

LINKAGE ASSEMBLY BOM (BRUSH DRIVE)

PARTS LIST							
ITEM	PART NO.	REQ'D	DESCRIPTION	ITEM	PART NO.	REQ'D	DESCRIPTION
1	210066	2	DRIVE HUB RETAINER BLT	40	710823	2	SC 1/4-20 X .50 NYL
2A	260002	2	PAD HOLDER-26B	41	710986	8	SC 3/8-16 X 1 ZINC
2B	260003	2	BRUSH-FEED THRU BASSINE	42	711128	1	SCR-ST-B HI-LO 8 X .62 ZINC
2C	260004	2	BRUSH-26B NYL	43	711160	3	SCR-HI/LO #10 X 5/8 ZINC
2D	260005	2	BRUSH-POLY GRIT 26B	44	711161	2	SCR-HI/LO #10 X 3/4 ZINC
2E	260006	2	BRUSH-STRATAGRIT.26B	45	711203	6	BLT-HH 1/4-20 X .62
3	260009	1	BATTERY TRAY	46	711210	2	BLT-HH 1/4-20 X 1.25 STL ZINC
4	260030	8	BUSHING-.5015 X .628 X .375 OI	47	711228	2	BLT-HH 5/16-18 X .75 STL ZINC
5	260036	12	PIN, RETAINER	48	711316	2	NUT-HEX 1/4-20 ST PL
6	260038PTD	1	MOTOR MOUNT WELDMENT RH	49	711334	2	NUT-HEX 1/2-13 ST PL
7	260039PTD	1	MOTOR MOUNT WELDMENT LH	50	711368	2	NUT-WING NYLOC 1/4-20 PL
8	260041	13	BUSHING-FLG .502 X .750 X .375	51	711375	3	NUT-NYLOC 3/8-16 1/2NUT
9	260042	1	ACTUATOR BAR WELDMENT	52	711425	9	NUT-FLANGED WIZZ 1/4-20
10	260049	4	LINKAGE BAR	53	711505	7	WSR-FLT 1/4
11	260053	2	CABLE-PUSH / PULL	54	711510	1	WSR-FLT .50 X 1.37 X .10
12	260066	2	BUSHING-FLG .377 X .687 X .406	55	711517	2	WSR-FLT .77 X 1.37 X .03
13	260068	1	SPACER-SPRING	56	711524	2	WSR-WAVE .52 X .87 X .01
14	260076	1	BRACKET ANDERSON PLUG	57	711535	6	WSR-HELICAL 1/4
15	260077	1	MOTOR FRAME WELDMENT	58	711545	2	WSR-HELICAL 5/16
16	260114	2	LINKAGE WELDMENT	59	711713	14	RET RING-E EXT .50
17	260123	1	CABLE BRACKET WELDMENT L.H.	60	711717	2	RET RING-E EXT .37
18	260124	1	CABLE BRACKET WELDMENT R.H.	61	712129	2	SCR-TR 1/4-20X 1.00 HWH
19	260137	1	SPRING-COMP .960 X 2.00 ZINC	62	712301	2	WSR-FLT .37 X .87 X .06 (WIDE)
20	260150	1	BATTERY LINER	63	712310	25	WSR-FLT .52 X .87 X .06 PL
21	260159	1	HOSE-VAC 1.5 X 78" WIRELOC	64	712667	1	NUT-HEX NYLOC 1/4-20 SS
22	260175	1	CABLE CONDUIT	65	740132	2	INSULATOR (GLASTIC)
23	260183	1	NUT 1/4 NPT NYL	66	740159	1	CIRCUIT BRKR-175 RED HOUSING
24	260203	1	CLAMP-HOSE 102120 MURRAY	67	740209	2	GEARMOTOR 24V 17B
25	260214	2	TANK CABLE ASY 260	68	740225	1	VAC MOTOR 6515-13 24V
26	260224	1	DRAIN HOSE 1/4 X 18 SILICONE	69	762073	1	BUSHING-.259 X .375 X .265
27	260315	1	LIFT CABLE BRACKET	70	762256PLT	2	NUT ADJ LH ZINC PLT
28	260377	1	SQUEEGEE CABLE	71	809444	1	CLIP-CORD
29	290017	1	MOULDED VAC MOTOR GASKET	72	828264	1	WASHER CUP
30	320248	2	CLEVIS, SLOTTED	73	828490	1	CLAMP-CRIMP 140R
31	320271	1	FITTING PP 90 3/8MPT 3/8HOSE	74	829067	2	CLAMP-CRIMP 560R
32	320272	2	NOZZLE BODY LOCKNUT	75	832996	1	TERMINAL BLOCK 2POLE VDE
33	320273	1	CLAMP-HOSE SHUT-OFF	76	833191	1	HOSE RUBBER FLEX 2X9
34	364-816	1	NUT-NYLOC 1/2-13 HALF	77	833265PLT	1	THREADED SPACER PLT ZINC
35	380064	1	RING, FOAM	78	833325	2	FITTING NYLON 90 1/4MPT 3/8HOSE
36	430035	2	DRIVE HUB	79	833638	2	BRASS STUD
37	450038-H	2	Z BKT 5.7 VDE ZINC	80	833725	2	CLIP-T
38	452037	2	CLAMP-CRIMP 170R SS	81	840011	1	VAC MOTOR COVER TOP
39	710180	2	SCR-MC 1/4-20 X .75 ZINC	82	840012	1	VAC MOTOR COVER BOTTOM

CONTROL PANELS (BRUSH DRIVE)

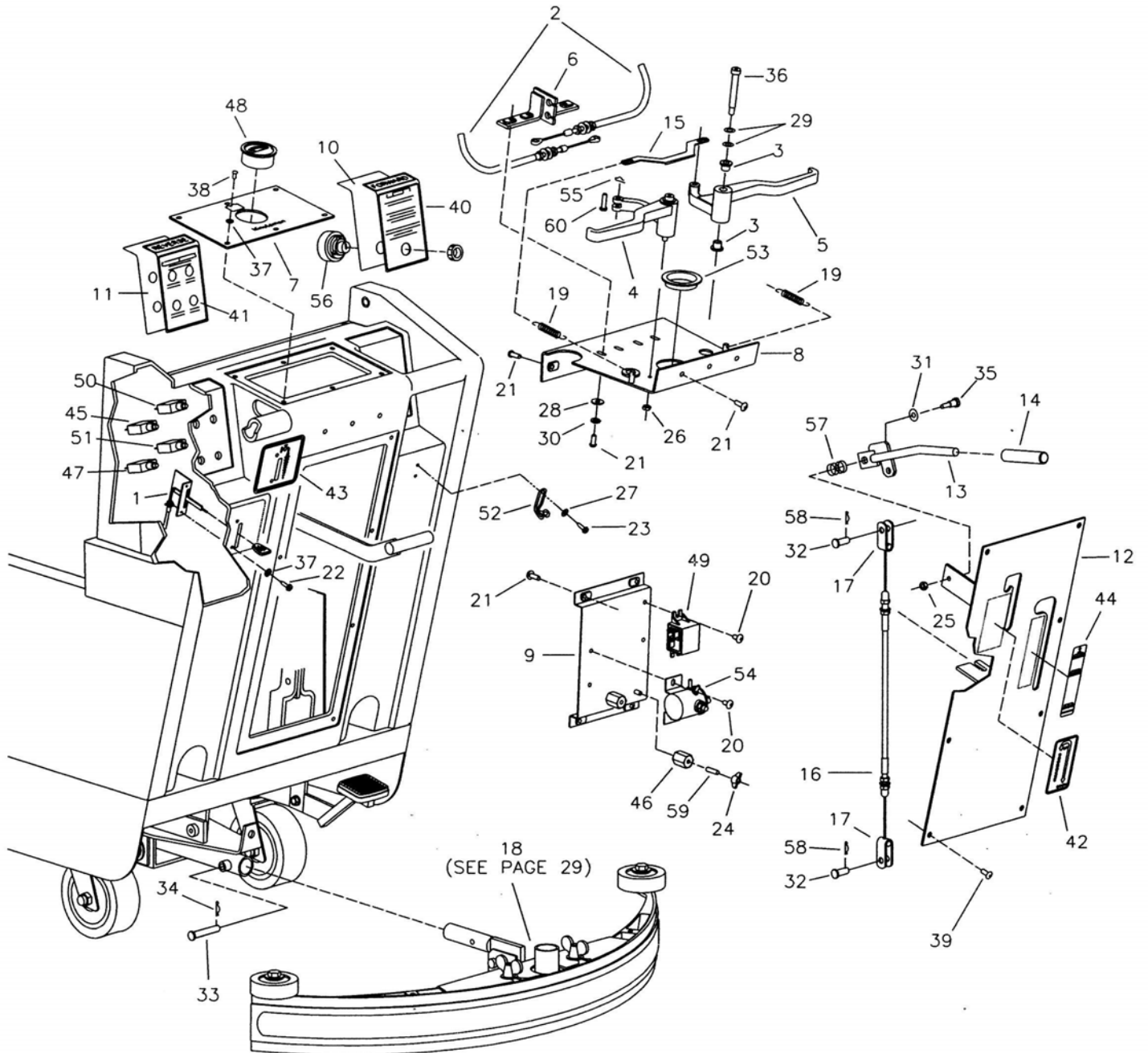

CONTROL PANELS BOM (BRUSH DRIVE)

PARTS LIST							
ITEM	PART NO.	REQ'D	DESCRIPTION	ITEM	PART NO.	REQ'D	DESCRIPTION
1	210045	1	CABLE-SOLUTION CONTROL	31	711575	1	WSR-FLT .31 X .75 X .06 STL
2	260053	2	CABLE-PUSH / PULL	32	711668	2	PIN-CLEVIS 3/8 X 1 11-141
3	260066	4	BUSHING-FLG .377 X .687 X .406	33	711671	1	PIN-CLEVIS .31 X 2.13 11-10
4	260069MCH	1	LEFT HANDLE MACHINED	34	711808	1	PIN-HAIRPIN COTTER #13
5	260070MCH	1	RIGHT HANDLE MACHINED	35	712070	1	BLT-SHOULDER 5/16 X 3/4 X 1/4-
6	260081	1	CABLE MOUNT WELDMENT	36	712100	2	BLT-SHOULDER 3/8 X 2.25
7	260084	1	DASHBOARD	37	712320	8	WSR .22 X .45 X .04 NYL
8	260099	1	CONTROL LEVER MOUNTING BRACKET	38	712540	6	SCR-MC 10-24 X .37 SS TH
9	260173	1	ELECTRICAL BOX MTG	39	712822	8	SCR-MC TR HD 10-24 X .50 SS
10	260255	1	SPEED CONTROL BRACKET 260TD	40	715608CE	1	DECAL-FORWARD TD CE
11	260658	1	BKT. CIRCUIT BREAKER PANEL, ES320	41	715602-1	1	DECAL, REVERSE ES260320
12	260284	1	REAR PANEL ASY 260TD	42	715603	1	DECAL-SQUEEGEE LIFT 260
13	260286	1	SQUEEGEE HANDLE WELDMENT	43	715604	1	DECAL-SOLUTION 260
14	260291	1	HANDLE GRIP 260TD	44	715605	1	DECAL-BRUSH POSITION
15	260325	1	HANDLE BRACKET	45	746006	1	CIRCUIT BRKR-3AMP PUSH BUTTON
16	260337	1	CABLE-SQUEEGEE	46	740132	2	INSULATOR (GLASTIC)
17	320248	2	CLEVIS, SLOTTED	47	740247	1	CIRCUIT BREAKER-30AMP PUSH BUTTON
18	281579	1	SQUEEGEE BLADE ASSY 32"	48	740216	1	GUAGE BATTERY COND
19	430051	2	SPRING-RETURN .313 X .438 X 2.	49	740241	1	CONTACT-24V 50AMP
20	710178	4	SCR-MC TR HD 1/4-20 X .50 ZINC	50	740238	1	CIRCUIT BREAKER-18AMP PUSH BUTTON
21	710180	17	SCR-MC 1/4-20 X .75 ZINC	51	742266	1	CIRCUIT BREAKER-60AMP PUSH BUTTON
22	711125	2	SCR-ST-B 10 X .50 NI	52	760286	1	WIRE FORMED HOOK
23	711161	2	SCR-HI/LO #10 X 3/4 ZINC	53	762400	1	BUSHING-HEYCO 1-5/8 X 2-1/8 X
24	711368	2	NUT-WING NYLOC 1/4-20 PL	54	788147	1	SOLENOID-24VDC
25	711373	1	NUT-NYLOC 1/4-20	55	809311	2	PIN-COTTER 7/64 X 1
26	711420	2	NUT-HEX JAM 5/16-18 STPL	56	747024	1	KEY SWITCH, SPST SOLDER LEADS
27	711503	2	WSR-FLT #10	57	833102	1	SPRING-KNOB .60 X .73 X 1.75 Z
28	711505	4	WSR-FLT 1/4	58	833374	2	PIN-HAIRPIN COTTER 3/8
29	711523	4	WSR-WAVE .37 X .68 X .08	59	833638	2	BRASS STUD
30	711544	4	WSR-HELICAL 1/4	60	881002	2	PIN-CLEVIS 11-083 ZINC

SOLUTION & RECOVERY TANK (TRACTION DRIVE)

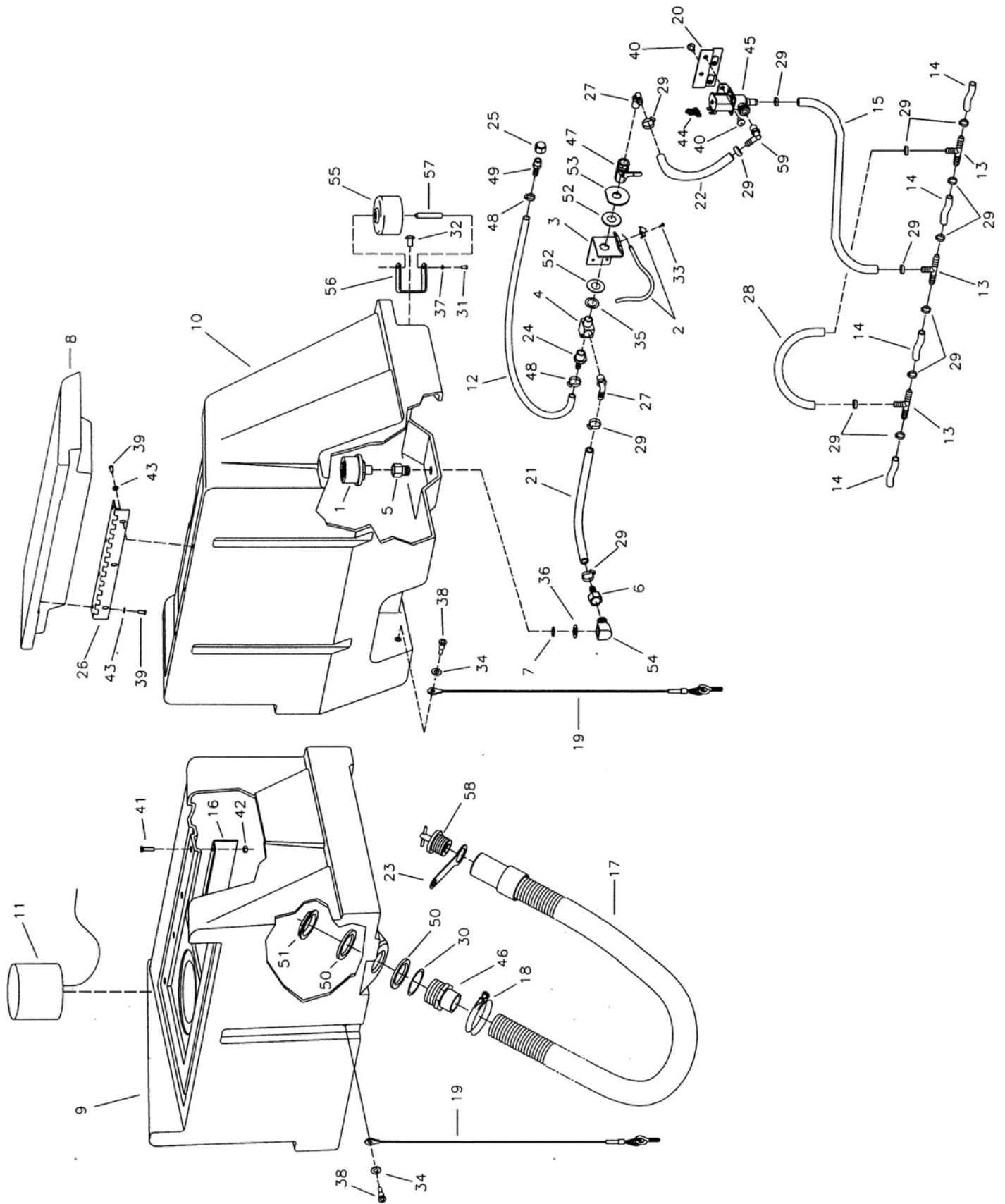

SOLUTION & RECOVERY TANK BOM (TRACTION DRIVE)

PARTS LIST			
ITEM	PART NO.	REQ'D	DESCRIPTION
1	130118	1	STRAINER-SOLUTION M3-40
2	210045	1	CABLE-SOLUTION CONTROL
3	210370	1	SOLUTION VALVE BRACKET
4	210408	1	FITTING BRASS TEE 3/8MPT&FPT
5	210409	1	FITTING BRASS 3/8MPT 3/8FPT
6	210410	1	FITTING BRASS 3/8FPT 3/8HOSE
7	210414	1	O RING 2-113
8	260029B	1	LID SOLUTION BURGUNDY
9	260091B	1	RECOVERY TANK, ES260320 BURGUNDY
10	260092B	1	SOLUTION TANK, ES260320 BURGUNDY
11	260156	1	FLOAT ASSEMBLY
12	260670	1	TUBING, PLASTIC 3/8 ID X 70"
13	260178	3	FITTING NYLON T 3/8HOSE
14	260179	4	HOSE-NYLOBRAID 3/8 X 2.38
15	260182	1	SOLUTION HOSE C/L 18"
16	260184	1	SUPPORT ANGLE
17	260202	1	HOSE ASY 260B NEW STYLE
18	260203	1	CLAMP-HOSE 102120 MURRAY
19	260214	2	TANK CABLE ASY 260
20	260669	1	BRACKET, SOLENOID ES320
21	281637	1	HOSE-WIRE REINF 3/8 X 11"
22	320254	1	SOLUTION HOSE
23	320269	1	STRAP, DRAIN PLUG RETAINING
24	342430	1	FITTING BRASS 3/8MPT 3/8HOSE
25	430114	1	FITTING NYLON CAP 1/4FPT
26	450021	1	HINGE
27	450040	2	ELBOW PLT 3/8MPTX3/8BARB
28	450055	1	HOSE NYLO 3/8ID X 9"
29	452037	15	CLAMP-CRIMP 170R SS
30	450081	1	WSR 1.908 X 2.41 X .03 SS
31	710353	2	SCR-MC 10-32 X .37 ZINC
32	710985	2	SC 3/8-16 X .62
33	711124	1	SCR-ST-B 10 X .37 NI
34	711506	2	WSR-FLT 5/16 (NARROW) ST PL
35	711512	1	WSR-FLT .75 X 1.37 X .08
36	711513	1	WSR-FLT .689 X 1.06 X .029 SS
37	711553	2	WSR-INT LOCK #10
38	712041	2	BLT-SHOULDER 1/4-20 X .44 X .3
39	712540	7	SCR-MC 10-24 X .37 SS TH
40	712560	4	SCR-MC 1/4-20 X .50 SS NYL
41	712563	4	SCR-MC 1/4-20 X 1.00 SS
42	712667	4	NUT-HEX NYLOC 1/4-20 SS
43	712764	7	WSR #10 SS
44	740482	1	DIODE ASY
45	740493	1	WATER VALVE 24VDC
46	760220MCH	1	1.5 ADAPTER MCH
47	809413MCH	1	SOLUTION VALVE
48	828490	2	CLAMP-CRIMP 140R
49	828952	1	FITTING PP 1/4MPT 3/8BARB
50	828970	2	WSR NEOP 1.87X2.4X.125
51	828971	1	NUT 1 1/2 PIPE THREAD
52	828975	1	WSR NEOP .75X1.5X.09
53	829463	1	S S WASHER
54	830062	1	FITTING BRASS 90 3/8MPT 3/8FPT
55	832896	2	GUIDE WHEEL
56	832949	2	BRACKET BUMPER
57	833254	2	BUMPER WHEEL AXLE
58	833316	1	DRAIN PLUG
59	833325	1	FITTING NYLON 90 1/4MPT X 3/8HOSE

MAINFRAME ASSEMBLY (TRACTION DRIVE)

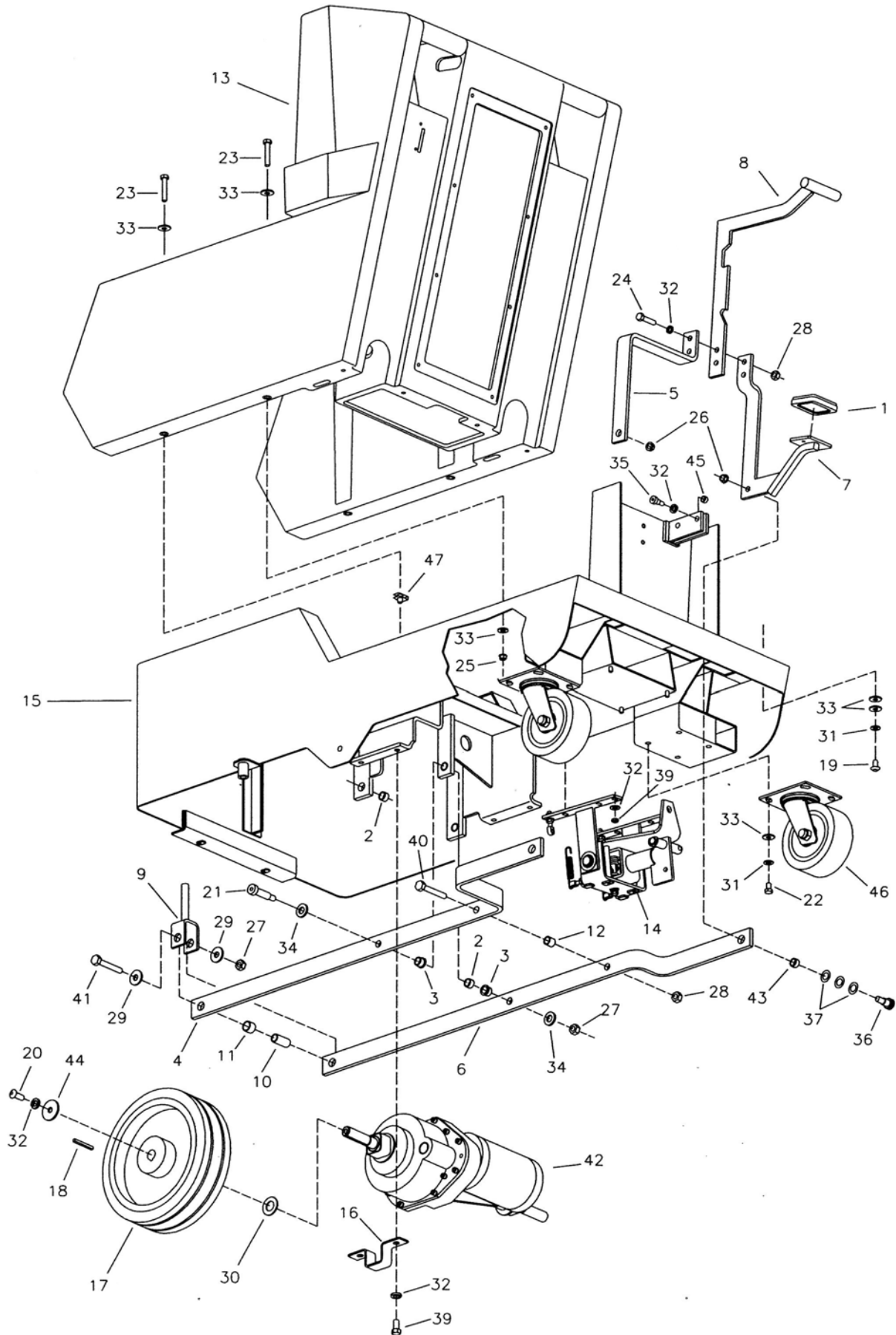

MAINFRAME ASSEMBLY BOM (TRACTION DRIVE)

PARTS LIST			
ITEM	PART NO.	REQ'D	DESCRIPTION
1	210142	1	PEDAL PAD
2	260030	5	BUSHING-.5015 X .628 X .375 OI
3	260041	2	BUSHING-FLG .502 X .750 X .375
4	260043	1	LIFT ARM, LEFT SIDE
5	260046	1	PEDAL BRACE
6	260044	1	LIFT ARM, RIGHT SIDE
7	260054	1	PEDAL WELDMENT
8	260055PTD	1	LIFT HANDLE WELDMENT
9	260075	1	YOKE WELDMENT
10	260125	1	BUSHING-YOKE .407 X 1.687 STL
11	260128	1	SPACER-YOKE
12	260141	1	SPACER-LIFT ARM
13	260256	1	BASE 260TD CHAR GREY
14	260660	1	SQUEEGEE LIFT ASSY, ES260320
15	260360	1	MAINFRAME MMAN 260 TD
16	260366	2	TRANSAXLE BRACKET 260TD
17	260370	2	WHEEL 10 X 2.75 X.75 BORE
18	260371	2	KEY 3/16 X 3/16 X 2.00
19	710196	4	SCR-MC 5/16-18 X .62
20	710986	2	SC 3/8-16 X 1 ZINC
21	710992	1	BLT-SHOULDER 1/2 X 1.25 X 3/8
22	711228	8	BLT-HH 5/16-18 X .75 STL ZINC
23	711232	4	BLT-HH 5/16-18 X 1.50
24	711250	2	BLT-HH 3/8-16 X 1.25 STL ZINC
25	711374	2	NUT-NYLOC 5/16-18
26	711375	2	NUT-NYLOC 3/8-16 1/2NUT
27	711380	2	NUT-NYLOC 3/8-16
28	711439	3	NUT-FLANGED WIZZ 3/8-16
29	711507	2	WSR-FLT .37 X 1.12 X .06
30	711512	2	WSR-FLT .75 X 1.37 X .08
31	711545	16	WSR-HELICAL 5/16
32	711546	10	WSR-HELICAL 3/8
33	711575	22	WSR-FLT .31 X .75 X .06 STL
34	711579	2	WSR-FLT .56 X 1.00
35	712081	2	BLT-SHOULDER 5/16-18 X .75 X .
36	712099PLT	2	BLT-SHOULDER 1/2 X 1/2
37	712310	6	WSR-FLT .52 X .87 X .06 PL
38	712680	4	NUT-HEX 5/16-18 SS
39	713042	4	BLT-HH 3/8-16 X 1.00 #5
40	713045	1	BLT-HH 3/8-16 X 1.75 #5
41	713048	1	BLT-HH 3/8-16 X 2.50 #5
42	744160	1	TRANSAXLE-13" 24V
43	762340	2	BUSHING-.502 X .625 X .270 STL
44	809226	2	WSR-FLT .40 X 1.50 X .12
45	809247	2	SPACER-.442 X .50 X .312
46	827110	2	CASTER 5 INCH
47	832829	2	NUT-U TYPE 5/16 X 18

LINKAGE ASSEMBLY (TRACTION DRIVE)

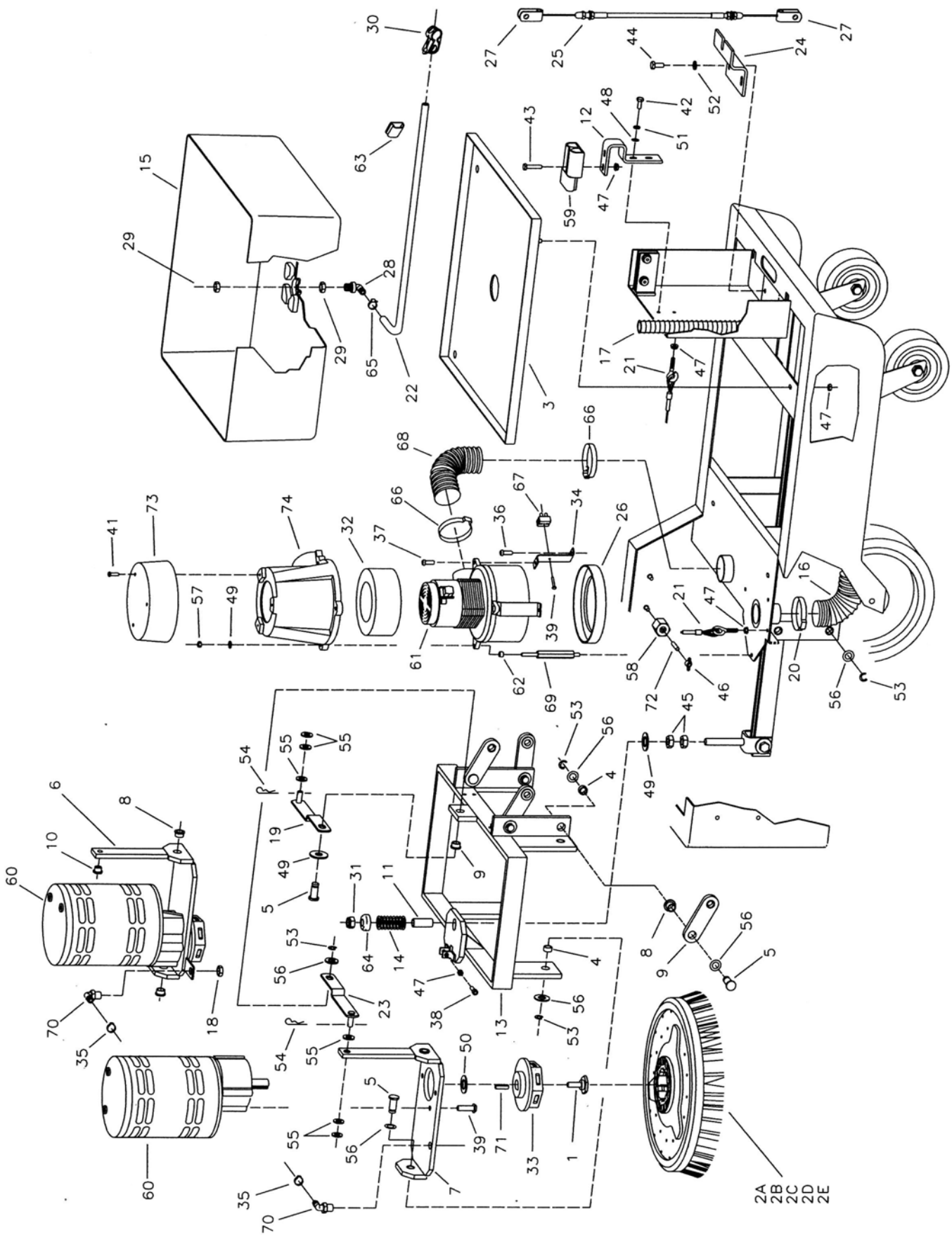

LINKAGE ASSEMBLY BOM (TRACTION DRIVE)

PARTS LIST							
ITEM	PART NO.	REQ'D	DESCRIPTION	ITEM	PART NO.	REQ'D	DESCRIPTION
1	210066	2	DRIVE HUB RETAINER BLT	36	710180	2	SCR-MC 1/4-20 X .75 ZINC
2A	260002	2	PAD HLDR-26B	37	710129	2	SCR-MC 8-32 X .50 ZINC
2B	260003	2	BRUSH-FEED THRU BASSINE	38	710823	2	SC 1/4-20 X .50 NYL
2C	260004	2	BRUSH-26B NYL	39	710986	8	SC 3/8-16 X 1 ZINC
2D	260005	2	BRUSH-POLY GRIT 26B	40	711128	1	SCR-ST-B HI-LO 8 X .62 ZINC
2E	260006	2	BRUSH-STRATAGRIT 26B	41	711160	3	SCR-HI/LO #10 X 5/8 ZINC
3	260009	1	BATTERY TRAY 14GA	42	711203	2	BLT-HH 1/4-20 X .62
4	260030	8	BUSHING-.5015 X .628 X .375 OI	43	711210	2	BLT-HH 1/4-20 X 1.25 STL ZINC
5	260036	13	PIN, RETAINER	44	711228	2	BLT-HH 5/16-18 X .75 STL ZINC
6	260038PTD	1	MTR MOUNT WELDMENT RH	45	711334	2	NUT-HEX 1/2-13 ST PL
7	260039PTD	1	MTR MOUNT WELMENT LH	46	711368	2	NUT-WING NYLOC 1/4-20 PL
8	260041	13	BUSHING-FLG .502 X .750 X .375	47	711425	10	NUT-FLANGED WIZZ 1/4-20
9	260049	4	LINKAGE BAR .312GA	48	711505	3	WSR-FLT 1/4
10	260066	2	BUSHING-FLG .377 X .687 X .406	49	711510	2	WSR-FLT .50 X 1.37 X .10
11	260068	1	SPACER-SPRG	50	711517	2	WSR-FLT .77 X 1.37 X .03
12	260076	1	BRACKET ANDERSON PLUG	51	711544	2	WSR-HELICAL 1/4
13	260077	1	MOTOR FRAME WELDMENT	52	711545	2	WSR-HELICAL 5/16
14	260137	1	SPRING-COMP .960 X 2.00 ZINC	53	711713	13	RET RING-E EXT .50
15	260150	1	BATTERY LINER	54	711808	2	PIN-HAIRPIN COTTER #13
16	260159	1	HOSE-VAC 1.5 X 78" WIRELOC	55	712301	6	WSR-FLT .37 X .87 X .06 (WIDE)
17	260175	1	CABLE CONDUIT	56	712310	25	WSR-FLT .52 X .87 X .06 PL
18	260183	2	NUT 1/4 NPT NYL	57	712667	1	NUT-HEX NYLOC 1/4-20 SS
19	260187	1	RETAINER BAR WELDMENT RH	58	740132	2	INSULATOR (GLASTIC)
20	260203	1	CLAMP-HOSE 102120 MURRAY	59	740159	1	CIRCUIT BRKR-175 RED HOUSING
21	260214	2	TNK CABLE ASY 260	60	740209	2	GEARMOTOR 24V 17B
22	260224	1	DRAIN HOSE 1/4 X 18 SILICONE	61	740225	1	VAC MTR 6515-13 24V
23	260250	1	RETAINER BAR WELDMENT LH	62	762073	1	BUSHING-.259 X .375 X .265
24	260315	1	LIFT CABLE BRACKET	63	809444	1	CLIP-CORD
25	260337	1	CABLE-SQUEEEGEE	64	828264	1	WASHER CUP
26	290017	1	MOLDED VAC MOTOR GASKET	65	828490	1	CLAMP-CRIMP 140R
27	320248	2	PIN-CLEVIS, SLOTTED	66	829067	2	CLAMP-CRIMP 560R
28	320271	1	FITTING PP 90 3/8MPT 3/8HOSE	67	832996	1	TERMINAL BLOCK 2POLE VDE
29	320272	2	NOZZLE BODY LOCKNUT	68	833191	1	HOSE RUBBER FLEX 2X9
30	320273	1	CLAMP-HOSE SHUT-OFF	69	833265PLT	1	THREADED SPACER PLT ZINC
31	364-816	1	NUT-NYLOC 1/2-13 HALF	70	833325	2	FITTING NYLON 90 1/4MPT 3/8HOS
32	380064	1	RING, FOAM	71	833621	2	KEY 1/4 X 1/4 X 1
33	430035	2	DRIVE HUB	72	833638	2	BRASS STUD
34	450038-H	2	Z BKT 5.7 VDE ZINC	73	840011	1	VAC MOTOR COVER TOP
35	452037	2	CLAMP-CRIMP 170R SS	74	840012	1	VAC MOTOR COVER BOTTOM

CONTROL PANELS (TRACTION DRIVE)

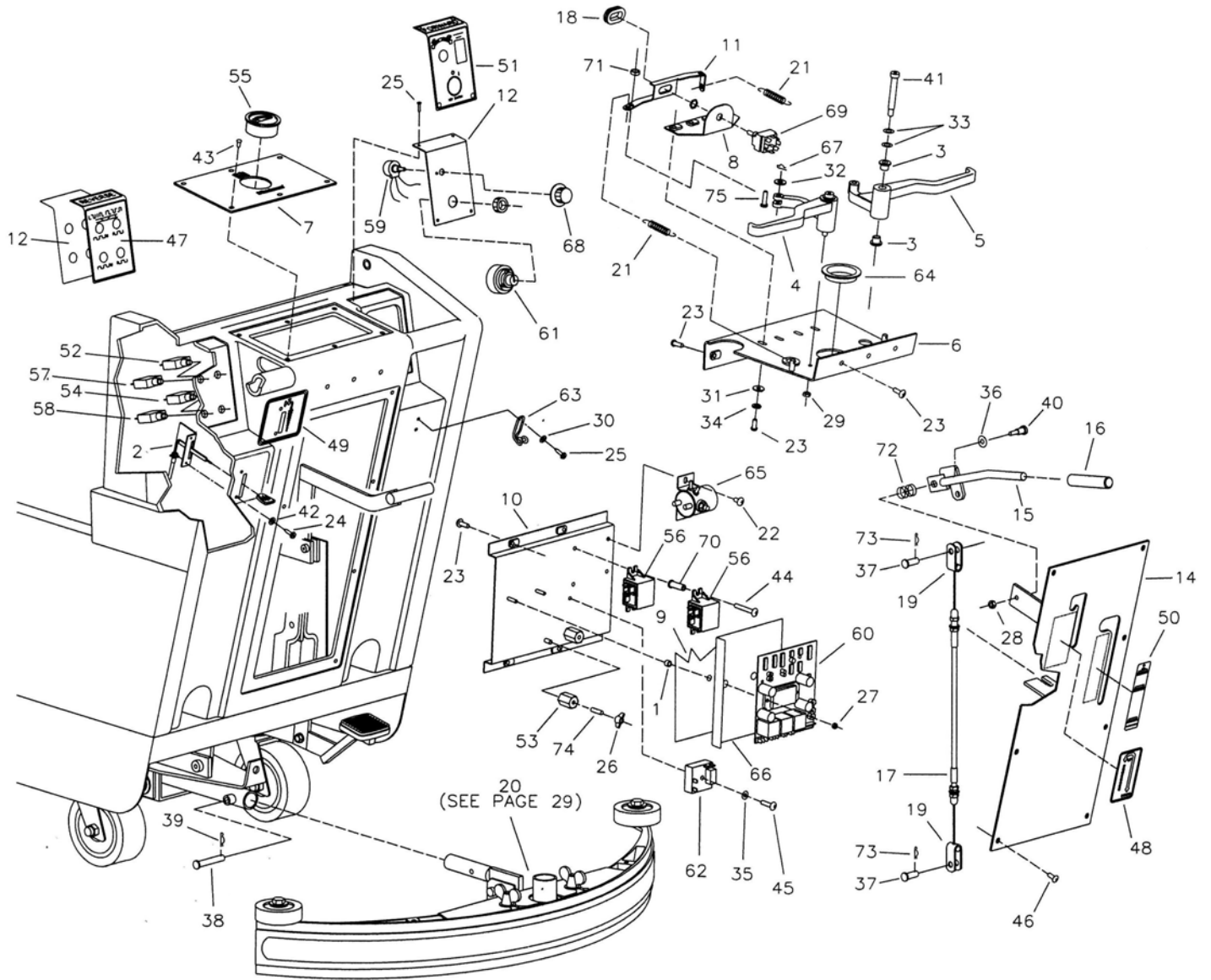

CONTROL PANELS BOM (TRACTION DRIVE)

PARTS LIST							
ITEM	PART NO.	REQ'D	DESCRIPTION	ITEM	PART NO.	REQ'D	DESCRIPTION
1	200340	2	SPACER-SCR BOARD	39	711808	1	PIN-HAIRPIN COTTER #13
2	210045	1	CABLE-SOLUTION CONTROL	40	712070	1	BLT-SHOULDER 5/16 X 3/4 X 1/4-
3	260066	4	BUSHING-FLG .377 X .687 X .406	41	712100	2	BLT-SHOULDER 3/8 X 2.25
4	260069MCH	1	LEFT HANDLE MACHINED	42	712320	2	WSR .22 X .45 X .04 NYL
5	260070MCH	1	RIGHT HANDLE MACHINED	43	712540	6	SCR-MC 10-24 X .37 SS TH
6	260099	1	CONTROL LEVER MOUNTING BRACKET	44	712570	2	SCR-MC 1/4-20 X 1.75 SS
7	260084	1	DASHBOARD	45	712814	1	SCR-MC 10-24 X .87 ZINC
8	260198	1	SWITCH BRACKET 260TD	46	712822	8	SCR-MC TR HD 10-24 X .50 SS
9	260210	1	MOISTURE GUARD SCR 260TD	47	715602-1	1	DECAL, REVERSE ES260320
10	260253	1	ELECTRICAL PANEL	48	715603	1	DECAL-SQUEEGEE LIFT 260
11	260254	1	SWITCH ACTUATOR 260TD	49	715604	1	DECAL-SOLUTION 260
12	260255	1	SPEED CONTROL BRACKET 260TD	50	715605	1	DECAL-BRUSH POSITION
13	260658	1	BKT, CIRCUIT BREAKER PANEL, ES320	51	715608CE	1	DECAL-FORWARD TD CE
14	260284	1	REAR PANEL ASY 260TD	52	740238	1	CIRCUIT BREAKER-18AMP PUSH BUTTON
15	260286	1	SQUEEGEE HANDLE WELDMENT	53	740132	2	INSULATOR (GLASTIC)
16	260291	1	HANDLE GRIP 260TD	54	740247	1	CIRCUIT BREAKER-30AMP PUSH BUTTON
17	260337	1	CABLE-SQUEEGEE	55	740216	1	GUAGE BATTERY COND
18	260274	1	GROMMET Z-421	56	740241	2	CONTACT-24V 50AMP
19	320248	2	CLEVIS, SLOTTED	57	746006	1	CIRCUIT BRKR-3AMP PUSH BUTTON
20	281579	1	SCV SQUEEGEE BLADE ASSY 32"	58	742266	1	CIRCUIT BREAKER-60AMP PUSH BUTTON
21	430051	2	SPRING-RETURN .313 X .438 X 2.	59	740804	1	POTENTIOMETER ASSY.
22	710178	4	SCR-MC TR HD 1/4-20 X .50 ZINC	60	740944-1	1	SPD CONT 24V 1203A225
23	710180	15	SCR-MC 1/4-20 X .75 ZINC	61	741005	1	SWITCH-KEY ON-OFF
24	711125	2	SCR-ST-B 10 X .50 NI	62	741037	1	RELAY-TRUE OFF 24V 5SEC
25	711161	6	SCR-HI/LO #10 X 3/4 ZINC	63	760286	1	WIRE FORMED HOOK
26	711368	2	NUT-WING NYLOC 1/4-20 PL	64	762400	1	BUSHING-HEYCO 1-5/8 X 2-1/8 X
27	711372	2	NUT-NYLOC 8-32	65	788147	1	SOLENOID-24VDC
28	711373	1	NUT-NYLOC 1/4-20	66	805637	1	SCR INSULATOR
29	711420	2	NUT-HEX JAM 5/16-18 STPL	67	809311	2	PIN-COTTER 7/64 X 1
30	711503	2	WSR-FLT #10	68	809874	1	KNOB SPEED CONTROL
31	711505	4	WSR-FLT 1/4	69	827060	1	SWITCH-DRIVE
32	711506	2	WSR-FLT 5/16 (NARROW) ST PL	70	828935	2	SPACER
33	711523	4	WSR-WAVE .37 X .68 X .08	71	832015	2	SPACER-.38 X .5 X .14
34	711544	4	WSR-HELICAL 1/4	72	833102	1	SPRING-KNOB .60 X .73 X 1.75 Z
35	711553	1	WSR-INT LOCK #10	73	833374	2	PIN-HAIRPIN COTTER 3/8
36	711575	1	WSR-FLT .31 X .75 X .06 STL	74	833638	2	BRASS STUD
37	711668	2	PIN-CLEVIS 3/8 X 1 11-141	75	881002	2	PIN-CLEVIS 11-083 ZINC
38	711671	1	PIN-CLEVIS .31 X 2.13 11-10				

SQUEEGEE LIFT MECHANISM ASSEMBLY (P.N. 260660)

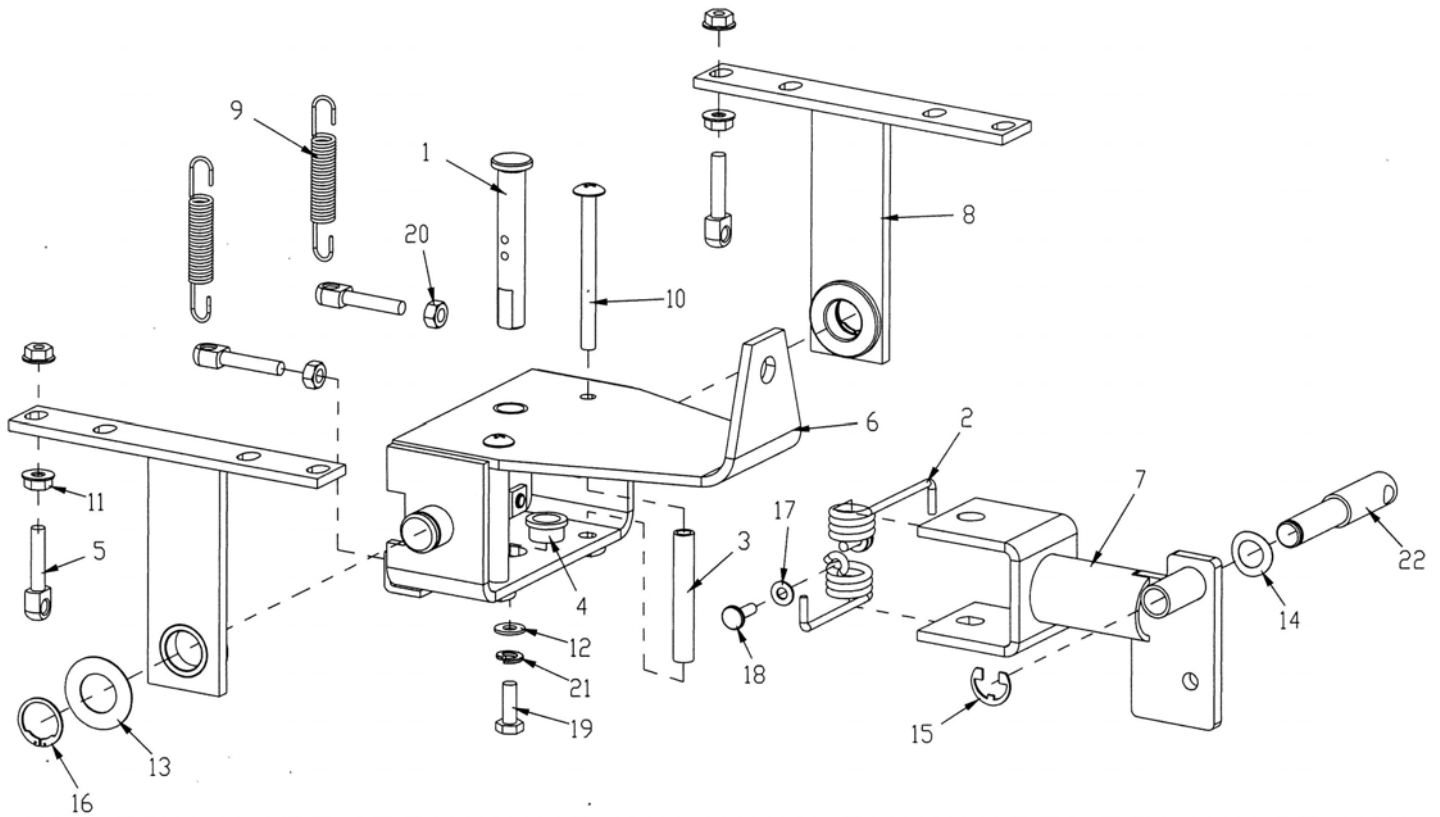

PARTS LIST			
ITEM	PART NO.	REQ'D	DESCRIPTION
1	210375	1	SWIVEL PIN
2	210391-1	2	SPRING-TORSION .563 X 2.595 SS
3	210400	2	SPACER-TUBE
4	260041	2	BUSHING-FLG .502 X .627 X .375
5	260292	4	BLT-SWING ZINC PLATED
6	260314	1	WELD-HOUSING SPRING
7	260659	1	YOKE WMT, SQUEEGEE, ES260320
8	320008	2	PIVOT BRACKET ASSEMBLY
9	430051	2	SPRING-RETURN .313 X .438 X 2.93 SS
10	710592	2	SCR-MC TH 1/4-20 X 3.00 SS
11	711425	4	NUT-FLANGED WIZZ 1/4-20 STL ZP
12	711504	1	WSR-FLT 1/4 SS
13	711517	2	WSR-FLT .77 X 1.37 X .03
14	711524	1	WSR-WAVE .52 X .87 X .01
15	711713	1	RET RING-E EXT .50
16	711715	2	RET RING-EXT .75
17	712320	2	WSR .20 X .45 X .048 NYL
18	712536	2	SCR-MC 10-24 X .62 SS
19	712562	1	BLT-HH 1/4-20 X .75 SS
20	712665	2	NUT-HEX 1/4-20 SS
21	712758	1	WSR-HELICAL 1/4 SS
22	762004	1	PIN, ADJUSTING

SQUEEGEE ADJUSTMENT MECHANISM ASSEMBLY (P.N. 241730)

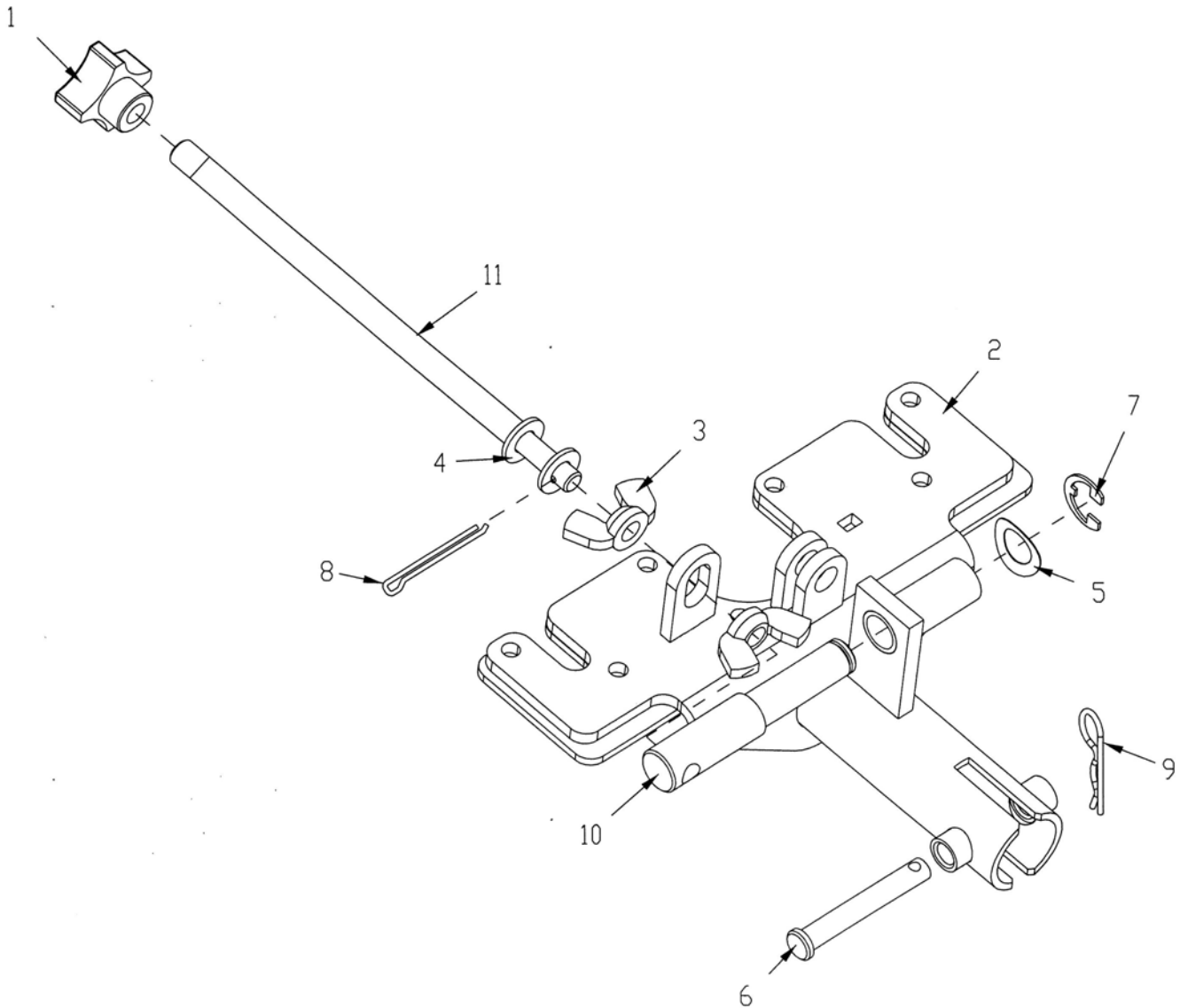

PARTS LIST			
ITEM	PART NO.	REQ'D	DESCRIPTION
1	241004	1	KNOB, 3/8"-16 FOUR PRONG
2	241751	1	WELD-MOUNT PLATE REAR SQUEEGEE
3	711367	2	NUT-WING 3/8-16 STPL
4	711506	2	WSR-FLT 5/16 (NARROW) ST PL
5	711524	1	WSR-WAVE .52 X .87 X .01
6	711671	1	PIN-CLEVIS .31 X 2.13 11-10
7	711713	1	RET RING-E EXT .50
8	711803	1	PIN-COTTER .06 X .75
9	711808	1	PIN-HAIRPIN COTTER #13
10	762005	1	ADJUSTING PIN, THREADED
11	762006	1	THREADED ROD, 3/8-16 X 7.50 LG

SQUEEGEE BLADE ASSEMBLY (P.N. 281579)

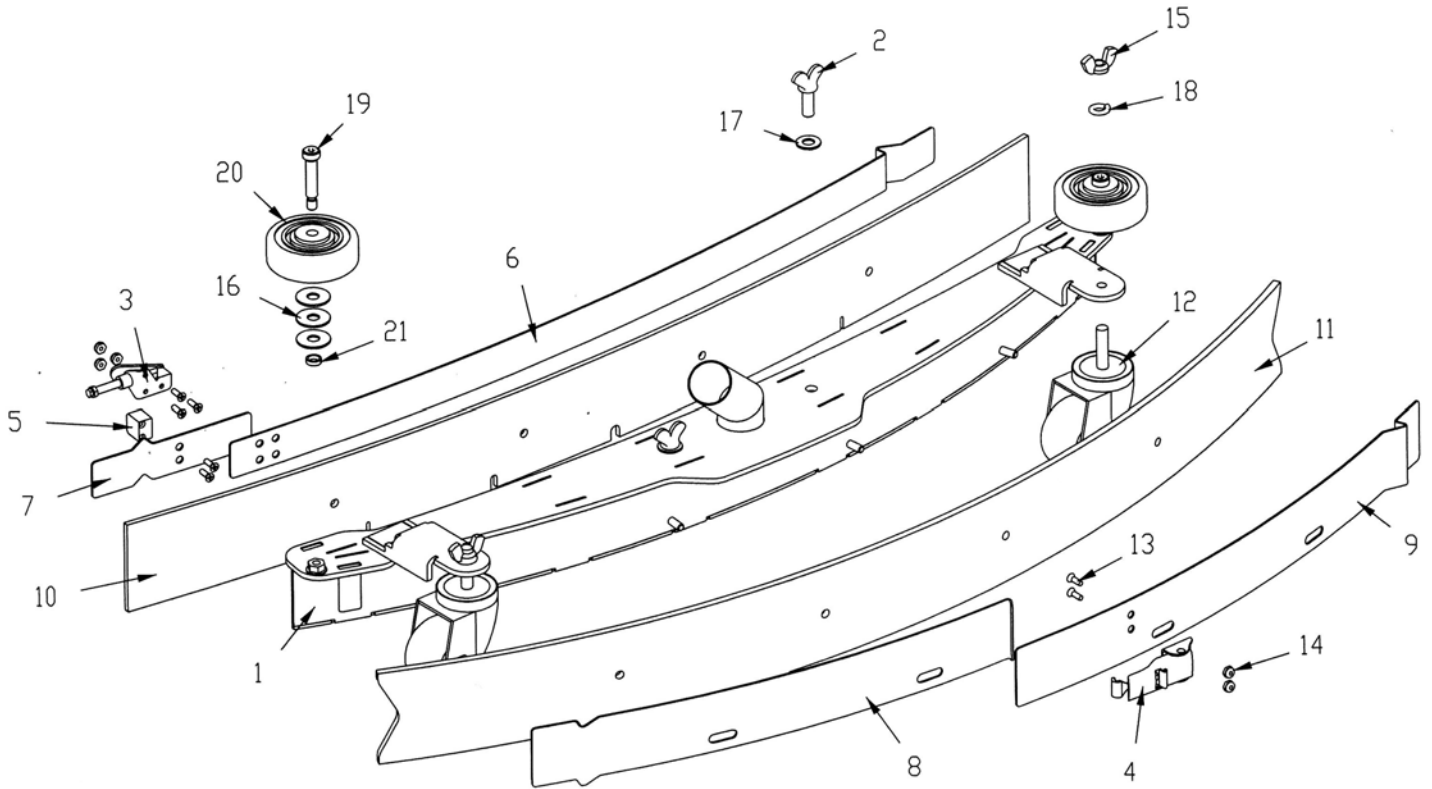

PARTS LIST			
ITEM	PART NO.	REQ'D	DESCRIPTION
1	241743	1	SQUEEGEE WMT ASSY, 32"
2	260206	2	WING BOLT 3/8-16 X 1.00 ZC PL
3	281074	1	CLAMP-SQUEEGEE TOGGLE 2800
4	281075	1	LATCH-SQUEEGEE 2800
5	281740	1	STOP BAR
6	281781	1	STRAP - FRONT CLAMP, 32"
7	281782	1	STRAP - FRONT STOP, 32"
8	281783	1	STRAP - REAR CATCH, 32"
9	281784	1	STRAP - REAR LATCH, 32"
10	281785	1	FRONT BLADE, SQUEEGEE GUM RUBBER, 32
11	281786	1	REAR BLADE, SQUEEGEE GUM RUBBER, 32
12	430325	2	CASTER-2.50 DIA
13	710530	7	SCR-MC 8-32 X .50 BRS
14	711026	5	NUT-HEX NYLOC 8-32 SS
15	711367	2	NUT-WING 3/8-16 STPL
16	711507	6	WSR-FLT .37 X 1.12 X .06
17	711515	2	WSR-FLT .406 X .812 X .0625
18	711546	2	WSR-HELICAL 3/8
19	712091	2	BLT-SHOULDER 3/8 X 1.5
20	808829	2	WHEEL-TRUCK
21	832015	2	SPACER-.38 X .5 X .14

WIRING DIAGRAM (STANDARD MODELS)

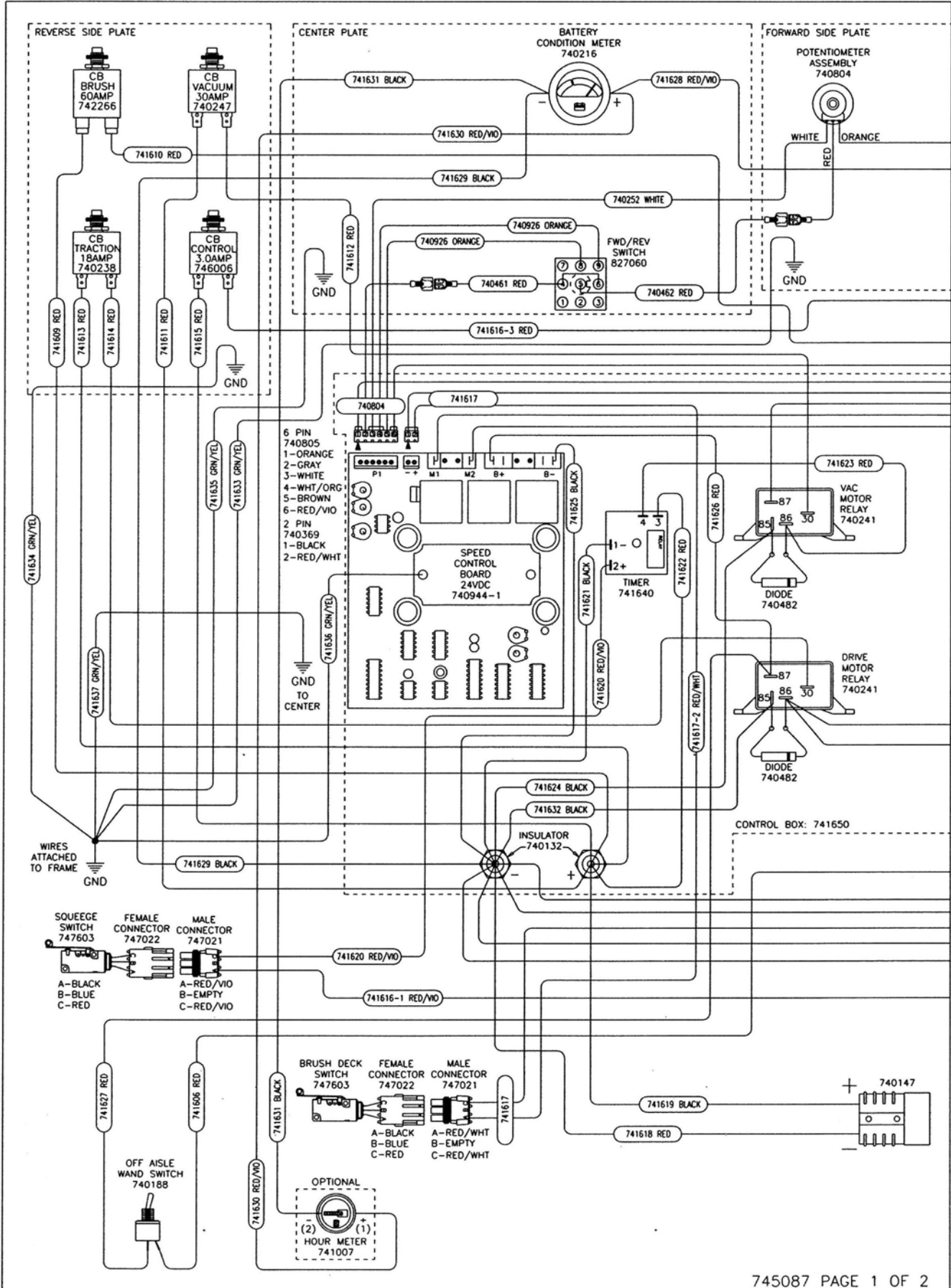

WIRING DIAGRAM (STANDARD MODELS) cont'd

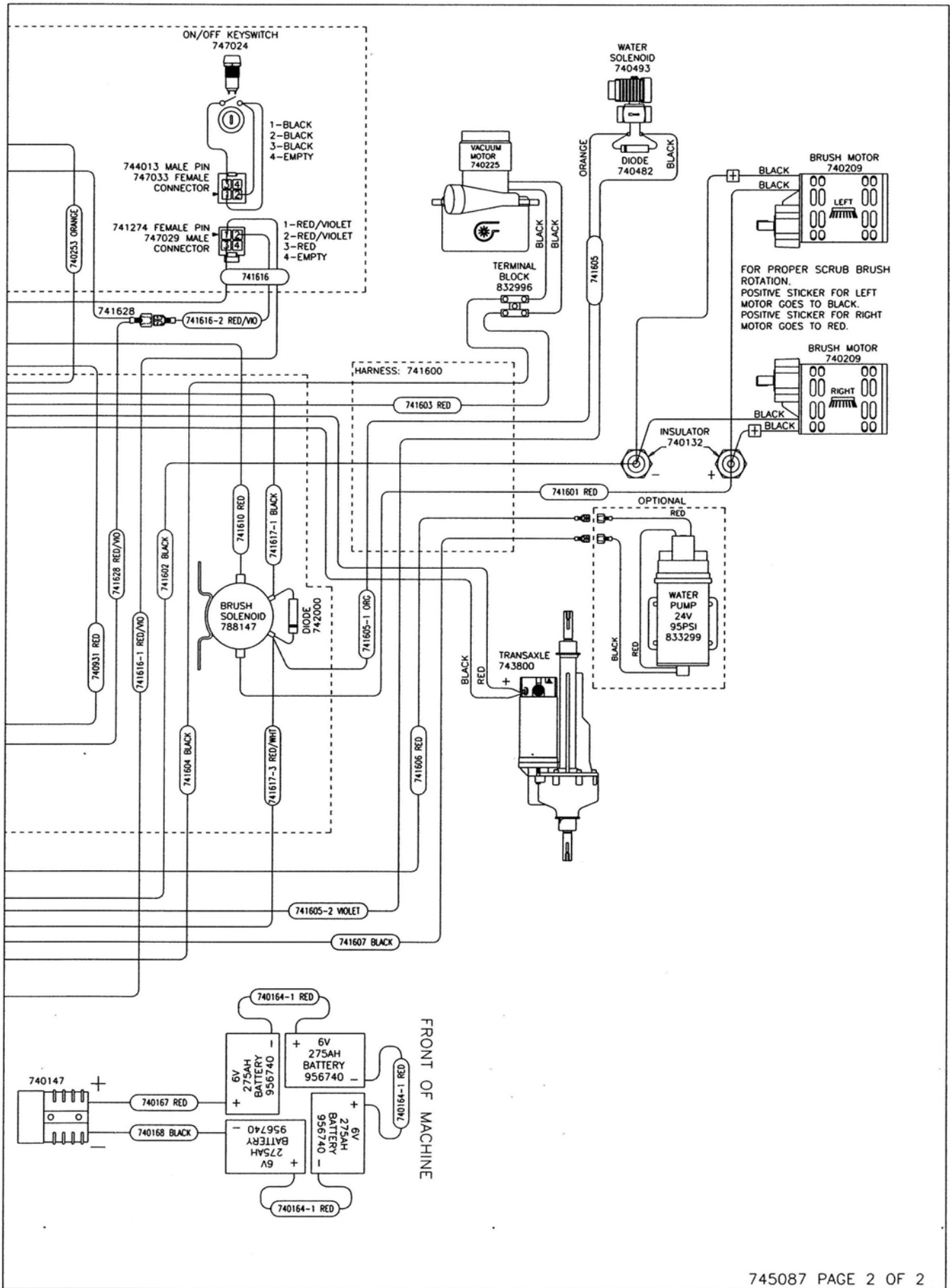

WIRING DIAGRAM (CE MODELS)

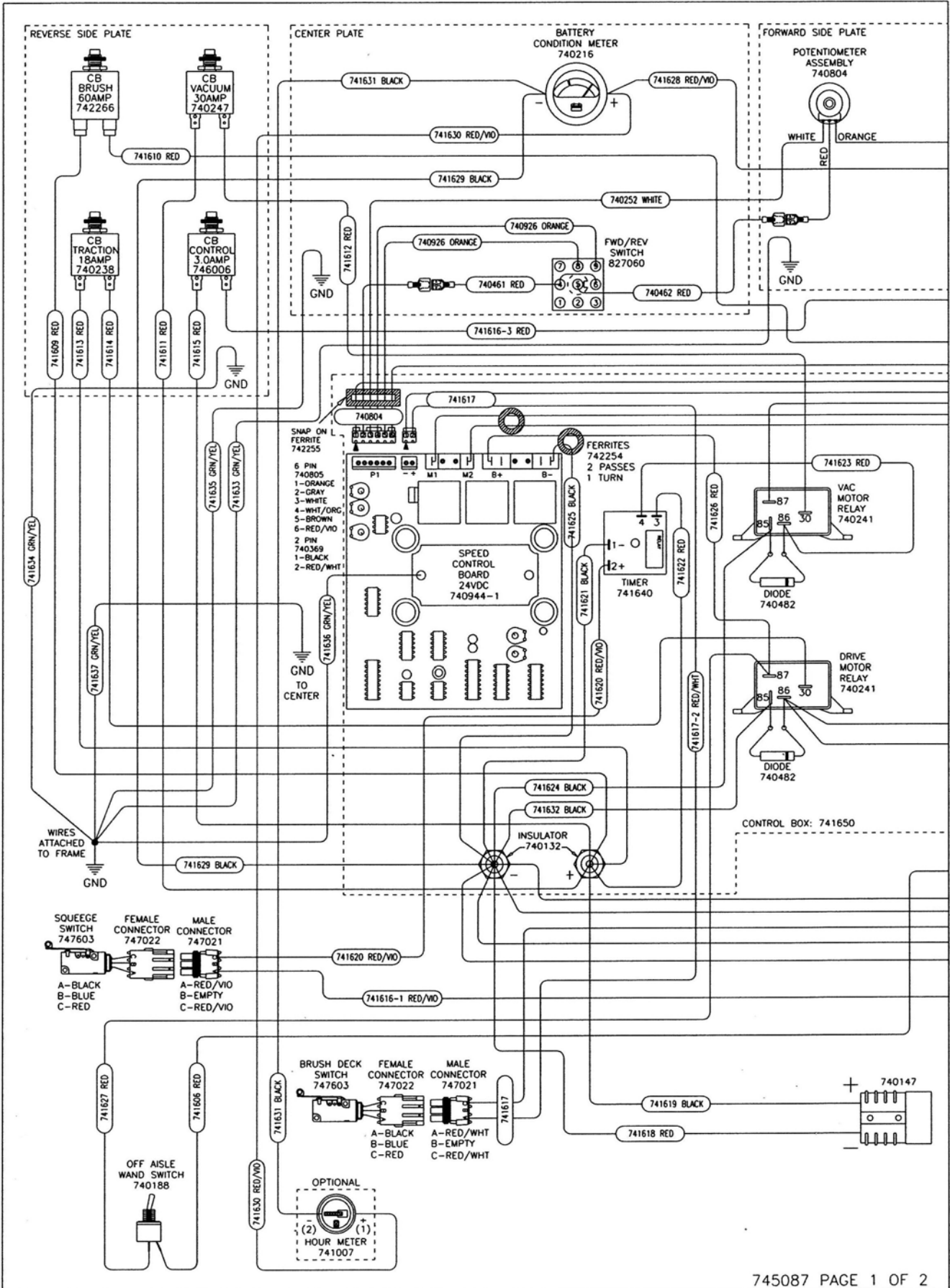

WIRING DIAGRAM (CE MODELS) cont'd

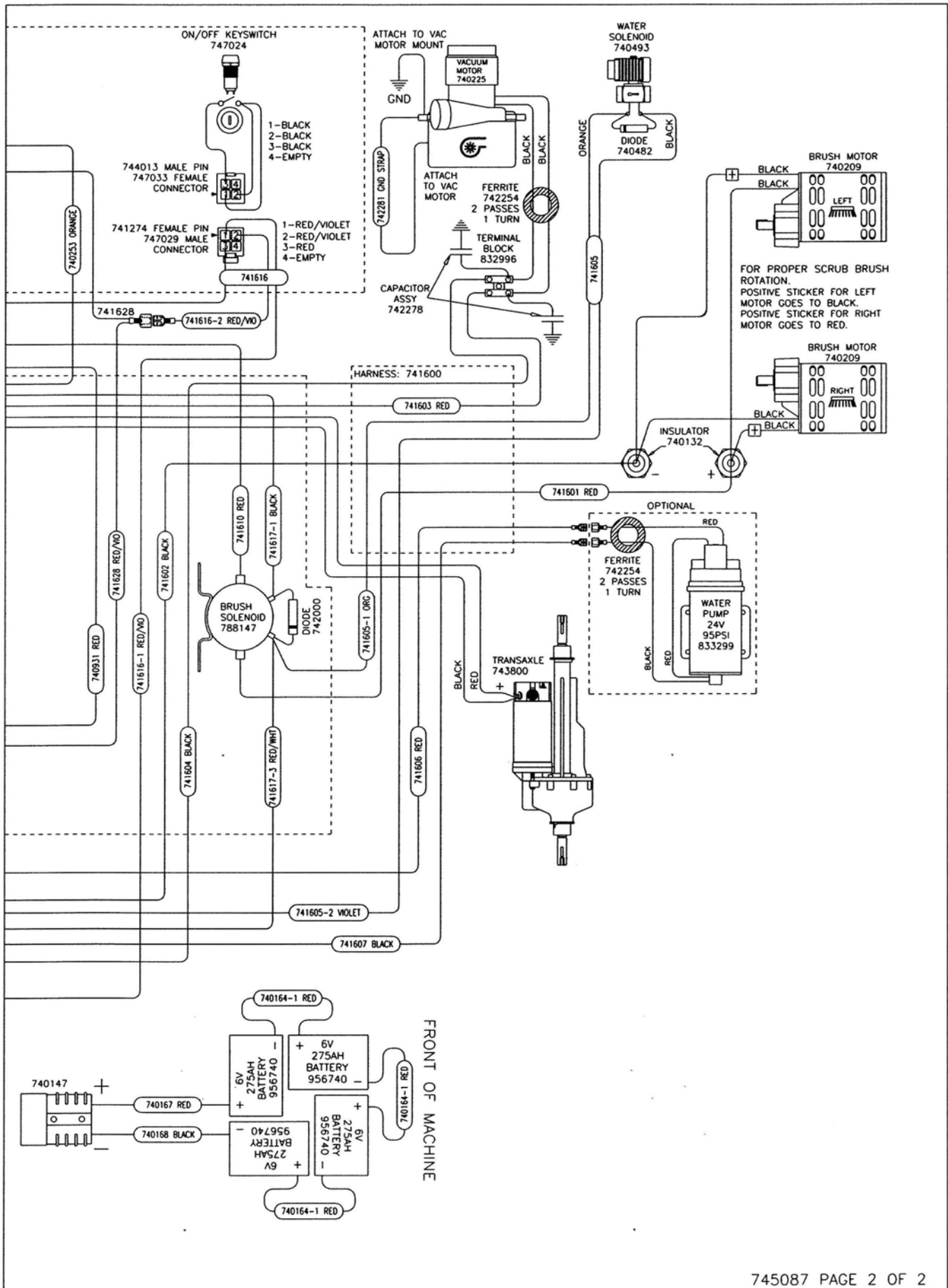



Minuteman International Made Simple Commercial Limited Warranty

Minuteman International, Inc. warrants to the original purchaser/user that the product is free from defects in workmanship and materials under normal use. Minuteman will, at its option, repair or replace without charge, parts that fail under normal use and service when operated and maintained in accordance with the applicable operation and instruction manuals. All warranty claims must be submitted through and approved by factory authorized repair stations.

This warranty does not apply to normal wear, or to items whose life is dependent on their use and care, such as belts, cords, switches, hoses, rubber parts, electrical motor components or adjustments. Parts not manufactured by Minuteman are covered by and subject to the warranties and/or guarantees of their manufacturers. Please contact Minuteman for procedures in warranty claims against these manufacturers.

Special warning to purchaser -- Use of replacement filters and/or prefilters not manufactured by Minuteman or its designated licensees, will void all warranties expressed or implied. A potential health hazard exists without original equipment replacement.

All warranted items become the sole property of Minuteman or its original manufacturer, whichever the case may be.

Minuteman disclaims any implied warranty, including the warranty of merchantability and the warranty of fitness for a particular purpose. Minuteman assumes no responsibility for any special, incidental or consequential damages.

This limited warranty is applicable only in the U.S.A. and Canada, and is extended only to the original user/purchaser of this product. Customers outside the U.S.A. and Canada should contact their local distributor for export warranty policies. Minuteman is not responsible for costs or repairs performed by persons other than those specifically authorized by Minuteman. This warranty does not apply to damage from transportation, alterations by unauthorized persons, misuse or abuse of the equipment, use of non-compatible chemicals, or damage to property, or loss of income due to malfunctions of the product.

If a difficulty develops with this machine, you should contact the dealer from whom it was purchased.

This warranty gives you specific legal rights, and you may have other rights which vary from state to state. Some states do not allow the exclusion or limitation of special, incidental or consequential damages, or limitations on how long an implied warranty lasts, so the above exclusions and limitations may not apply to you.

Cord Electric Group..... Three years parts, two years labor, ninety days travel (Not to exceed two hours)

- Exceptions**..... Port-A-Scrub, one year parts, six months labor
- MPV 13, one year parts
- MPV 14 and 18, two years parts, one year labor
- RapidAir blower, one year parts, one year labor
- Explosion-Proof Vacuum, one year parts, one year labor
- Pneumatic Vacuums, three years parts, one year labor

Battery Operated Group..... Three years parts, two years labor, ninety days travel
(Not to exceed two hours)

- Exceptions**..... Sweepers, one year parts, one year labor, ninety days travel
(Not to exceed two hours)

Internal Combustion Group....One year parts, one year labor, ninety day travel
(Not to exceed two hours)

Replacement Parts.....Ninety days

Batteries.....0-3 months replacement, 4-12 months pro-rate

Polypropylene Plastic Tanks...Ten years, no additional labor

A Member of the Hako Group of Companies

111 South Rohlwing Road · Addison, Illinois 60101 USA
Phone 630- 627-6900 · Fax 630- 627-1130
E-Mail, www.minutemanintl.com

988020
Rev * 01/06
Printed in USA